

EWF36A Fireplace

Homeowner's Installation and Operating Manual

SAFETY NOTICE: IF THIS APPLIANCE IS NOT PROPERLY INSTALLED, OPERATED AND MAINTAINED, A HOUSE FIRE MAY RESULT. TO REDUCE THE RISK OF FIRE, FOLLOW THE INSTALLATION INSTRUCTIONS. FAILURE TO FOLLOW INSTRUCTIONS MAY RESULT IN PROPERTY DAMAGE, BODILY INJURY OR EVEN DEATH. CONTACT LOCAL BUILDING OFFICIALS ABOUT RESTRICTIONS AND INSTALLATION INSPECTION REQUIREMENTS IN YOUR AREA.



CFM Specialty Home Products

410 Admiral Blvd. • Mississauga, Ontario, Canada L5T 2N6 • 905-670-7777
www.majesticproducts.com • www.vermontcastings.com

Do Not Discard This Manual: Retain for Future Use

Introduction

Thank you for purchasing a Vermont Castings, EWF36A fireplace. An efficient fireplace carefully engineered to bring you the latest in wood combustion principles and modern foundry technology.

You can count on years of comfortable heating and pleasurable fire viewing if you treat it properly and operate the EWF36A according to the directions in this owner's guide.

The EWF36A is listed by Underwriter's Laboratories, and is in compliance with the standards set forth by the Federal Environmental Protection Agency, 40 CFR Part 60.532(b), as stated on the permanent label attached to each appliance.

This manual describes the installation and operation of the EWF36A wood heater. This heater meets the US Environmental Protection Agency's emission limits for wood heaters sold after July 1, 1990. Under specific test conditions this heater has been shown to deliver heat at a rate ranging from 11,000 to 68,600 Btu's/hr.

For more complete details on the EWF36A performance and specifications, please refer to Page 3.

The EWF36A is designed, tested and listed for burning wood. Do not burn other fuels.

We recommend that you hire a professional installer certified by Wood Energy Technical Training (WETT) to install your EWF36A, or to advise you on the installation should you attempt to install it yourself.

Please read the appropriate sections of this manual before you install and use your EWF36A. For information on operation and maintenance of the EWF36A, refer to Pages 17 and 20.

The EWF fireplace can use 100% outside air with the AKMST Outside Air Kits installed.

Failure to follow these instructions may result in property damage, bodily injury or even death.

Save These Instructions for Future Reference

Table of Contents

Introduction	2
Safety Information	3
Specifications	4
Planning Information	7
Installation	8
Operation	18
Maintenance	22
Replacement Parts	27
Optional Accessories	29
Warranty	30

Proposition 65 Warning: Fuels used in gas, woodburning or oil fired appliances, and the products of combustion of such fuels, contain chemicals known to the State of California to cause cancer, birth defects and other reproductive harm.
California Health & Safety Code Sec. 25249.6

Safety Information

Please Read This Manual Before Installing and Using Fireplace

IMPORTANT: Read all instructions and warnings carefully before starting installation. Failure to follow these instructions may result in a possible fire hazard and will void the warranty.

Description

The EWF36A fireplace is a solid fuel, woodburning, heat circulating fireplace.

Precautions

Vermont Castings, Majestic Products fireplaces and component parts have been highly tested and will operate safely when installed in accordance with instructions provided in this manual. Carefully read and understand all instructions **before** beginning installation.

If you notice any damage to fireplace or component parts, immediately report damage to your Vermont Castings, Majestic Products dealer.

Only use Vermont Castings, Majestic Products components or the warranty will be voided and a fire hazard may be created.

Vermont Castings, Majestic Products warranty will be voided by and Vermont Castings, Majestic Products disclaims any responsibility for the following actions:

- **Installation of any damaged fireplace or chimney component;**
- **Modification of fireplace, chimney assembly or any component parts thereof;** (except for chase flashings as detailed in Vermont Castings, Majestic Products' Chimney Top installation instructions).
- **Installation other than as instructed by Vermont Castings, Majestic Products; or**
- **Installation and/or use of any component part not manufactured or approved by Vermont Castings, Majestic Products in combination or assembly with a Vermont Castings, Majestic Products fireplace system, notwithstanding any independent testing laboratory or other third party approval of such component parts or accessory.**

Any such action may possibly cause a fire hazard.

Consult local building codes to ensure that you are in compliance **before** installing the fireplace.

This fireplace and chimney system must be vented to the out-of-doors.

Do not obstruct or modify air inlets/outlets in any manner.

Do not install combustible materials on any of the black fireplace surround.

Burn only solid wood fuel.

The EWF36A is intended for operation with the doors closed or fully open only with the optional spark screen in place.

Do not install a solid fuel burning insert or other products not specified for use with this fireplace.

This fireplace is not approved for installation in mobile homes.

NOTE: Hairline cracks in hearth brick and ash lips are not a safety issue and do not need to be replaced.

Drafts

The fireplace should not be located in areas that create drafts (ie: frequently opened doors and central heating air inlets/outlets) that hamper the normal flow of air into the fire.

EWF36A Listed
UL / ULc127 Standard for Factory Built Fireplaces

Specifications

EWF36A

Range of heat output* 11,300 - 75,500 Btu/hr
 Maximum heat output** in excess of 100,000 Btu/hr
 EPA emissions rating (g/h, catalytic) 2.4*
 Area heated*** Up to 2500 sq. ft. (558 sq. m)
 Size of wood splits 18" - 24" (450-610mm)
 Fuel Capacity 40lbs. (18kg)
 Loading Front
 Flue size 8" (200mm)
 Fireplace weight 741lbs.
 Primary Air Control Manual
 Glass panel High-temperature ceramic
 Flue exit position Top
 Blower rating 160cfm. (115V, 60Hz)

*Under specific test conditions used during EPA emissions standard testing.

**This value can vary depending on how the unit is operated, and the type and moisture content of the fuel used. Figure shown is based on maximum fuel consumption obtained under laboratory conditions and on average efficiencies.

***These values are based on operation in building-code conforming homes under typical winter climate conditions. If your home is of nonstandard construction (e.g. unusually well insulated, not insulated, built under ground, etc.) or if you live in a more severe or more temperate climate, these figures may not apply. Since so many variables affect performance, consult your Vermont Castings' Authorized Dealer to determine realistic expectations for your home.

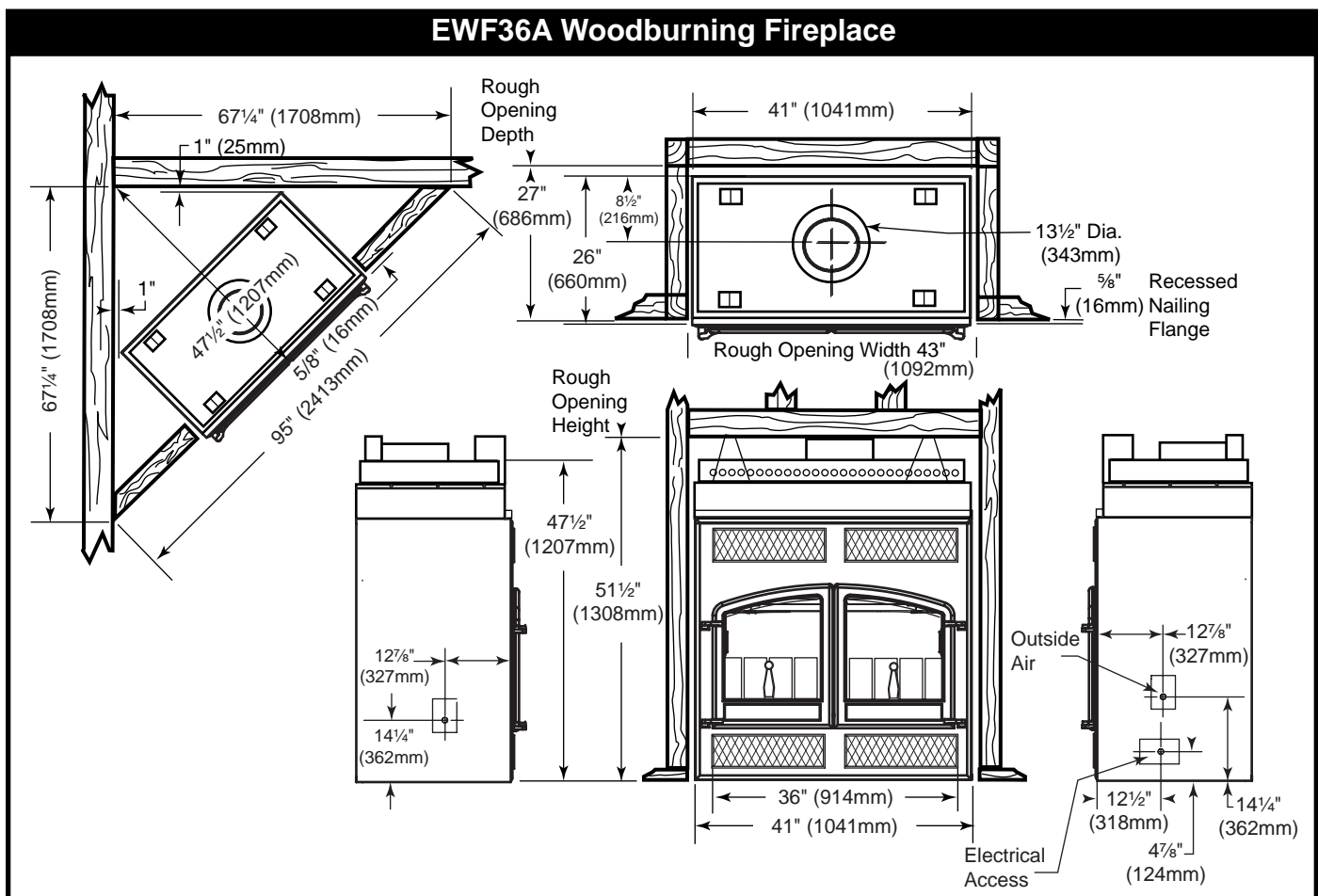
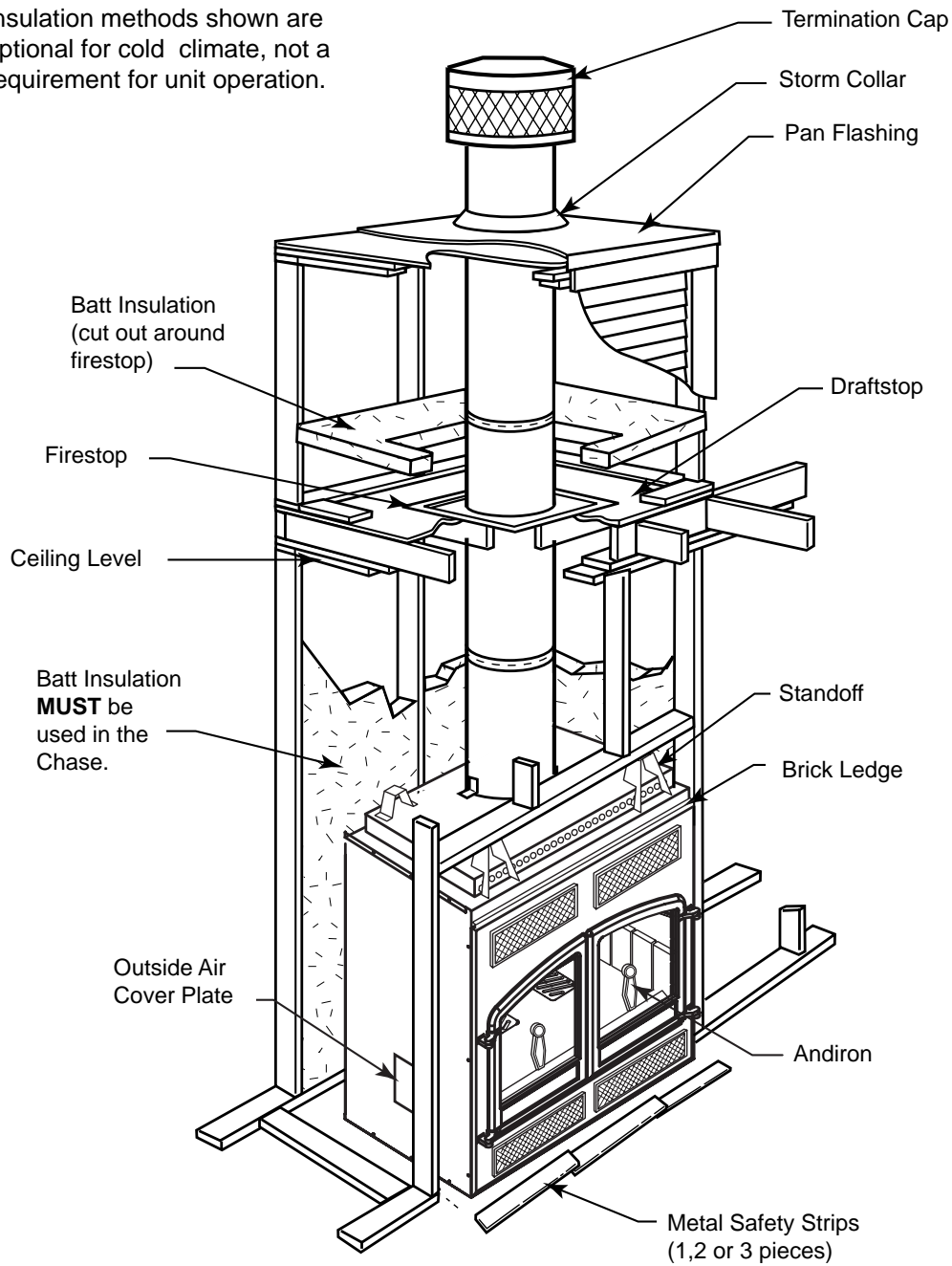

Fig. 1 EWF36A specifications and framing.

Chase Installation

Insulation methods shown are optional for cold climate, not a requirement for unit operation.



FP554a

Fig. 2 Fireplace and chase parts identification.

Chimney Requirements - Offset Installations

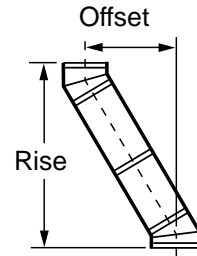
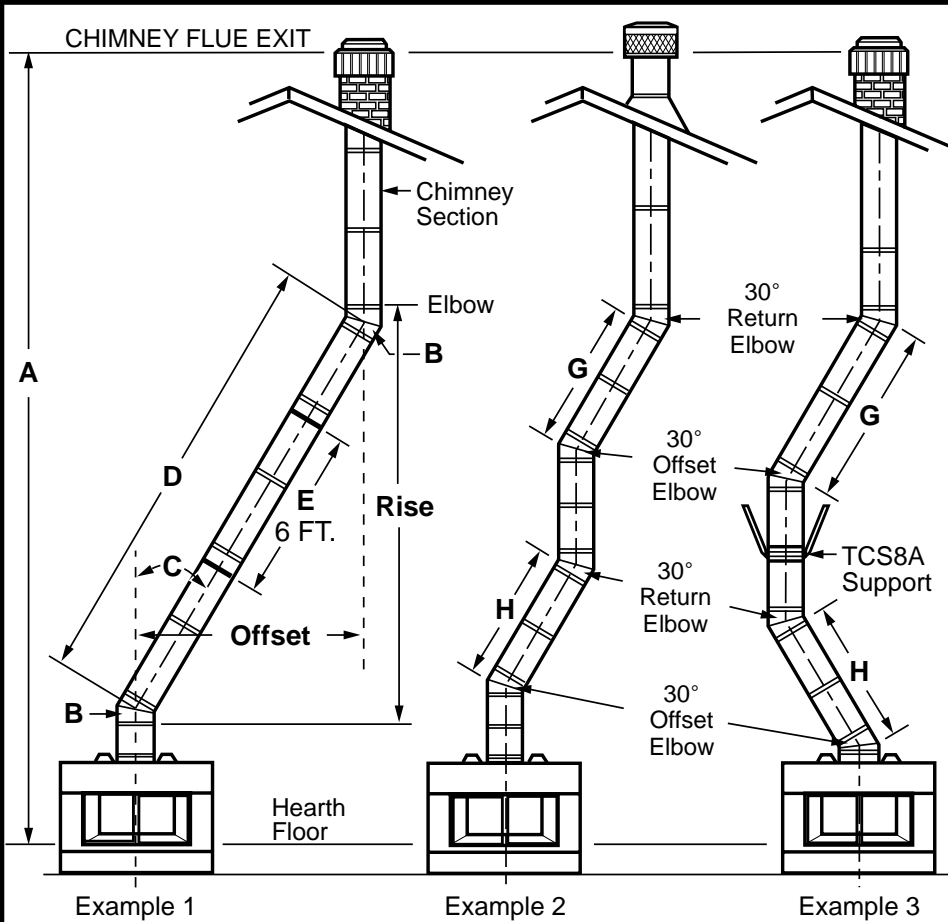

FP282

30° Elbow Offsets

					Chimney Support	Offset	Rise
1'	1½'	3'	4'				
0	0	0	0	0	0	3"	11"
1	0	0	0	0	0	8¼"	20"
0	1	0	0	0	0	11¼"	25¼"
2	0	0	0	0	0	13½"	29¼"
1	1	0	0	0	0	16½"	34¼"
0	0	1	0	0	0	20¼"	40¾"
2	1	0	0	0	0	21¾"	43½"
0	0	0	1	0	0	26¼"	51¼"
0	1	1	0	0	0	28½"	55¼"
1	0	0	1	0	0	31½"	60¼"
0	1	0	1	0	0	34½"	65½"
0	0	2	0	0	0	37½"	70¾"
1	1	0	1	1	1	41½"	77¾"
0	0	1	1	1	1	45"	83¾"
0	1	2	0	1	1	47¼"	87½"
0	0	0	2	1	1	51"	94"
0	1	1	1	1	1	53¼"	98"
0	0	3	0	1	1	56¼"	103¼"
0	1	0	2	1	1	59¼"	108½"
0	0	2	1	1	1	62¼"	113½"
0	1	3	0	1	1	64½"	117½"
0	0	1	2	1	1	68¼"	124"
0	1	2	1	1	1	70½"	128"
0	0	0	3	1	1	74¼"	134½"
0	1	1	2	2	1	78"	140¾"
0	0	3	1	2	1	81"	146"
0	1	0	3	2	1	84"	151¼"
0	0	2	2	2	1	87"	156½"
0	1	3	1	2	1	89¼"	160¼"
0	0	1	3	2	1	93"	166¾"
0	1	2	2	2	1	95¼"	170¾"
0	0	0	4	2	1	99¼"	177¾"
0	1	1	3	2	1	101¼"	181¾"
0	0	3	2	2	1	104¼"	186¼"
0	1	0	4	2	1	107¼"	191½"
0	0	2	3	2	1	110¼"	196¾"
0	1	3	2	3	1	114"	203¼"
0	0	1	4	3	1	117¾"	209¾"
0	1	2	3	3	1	120"	213½"
0	0	0	5	3	1	123¾"	220"

Notes: G + H cannot exceed 20 feet.
Air Space Clearances: "S" Series (3-wall) = 2" Min. to Combustibles

Illustration Key

The following safety rules apply to offset installations (letters correspond with illustration above):

A. Height of the chimney is measured from the hearth to the chimney exit.

	<u>EWF36A</u>
Maximum:	50'
Minimum:	
Without Elbows	17'0"
With 2 Elbows*	19'0"
With 4 Elbows*	21'0"

B. Do not use more than 4 elbows per chimney.

Attach the straps of the return (top) elbow to a structural framing member.

The offset (first) elbow of any pair does not have straps.

C. The chimney cannot be more than 30° (45° in Canada) from the vertical plane in any installation*.

D. The maximum length of the angled run of the **total** chimney system is 20 feet. (G plus H cannot exceed 20 feet.)

E. A chimney support (Model TCS8A) is required every 6 feet of angled run of chimney. Chimney supports are required for every 30 feet and 60 feet of vertical chimney height above the hearth.

Determine the offset distance of your chimney arrangement from the centerline of the fireplace to the centerline of the chimney where it is to pass through the first ceiling.

NOTE: This offset distance may not be your full offset distance. See Examples 2 and 3.

FP269

Fig. 3 Chimney system requirements.

Planning Information

Planning an installation is very important to ensure safety and to save time and money. An installer must predetermine where a fireplace will be set and how the chimney system will be run.

Mounting the Fireplace

The fireplace is shipped with lifting handles attached to each side with lifting straps. **NOTE:** The lifting straps are intended for lifting unit off of the skid and final positioning. Unit should remain on skid until final positioning. After fireplace is in position, the lifting handle and straps may be removed or left in place.

A fireplace may only be mounted on the following surfaces:

1. A flat combustible surface.
2. A raised wooden platform.
3. A concrete block or other solid object placed beneath each of the four (4) corners of the fireplace.

The fireplace **must** be spaced 1" from a combustible back wall and 1" from a combustible side wall or support. (Page 13, Fig. 17)

	TRIPLE WALL	TOTAL LENGTH (L _T)	INSTALLED LENGTH (L ₁)
L _T			
L ₁	81	11½"	10½"
L ₁	818	17½"	16½"
L ₁	83	35½"	34½"
L ₁	84	47½"	46½"

FP288a

Fig. 4 Installed lengths of chimney sections.

Determine how the chimney will be run, length of run and chimney components required to complete the job. (Fig. 4) **Never** install a chimney below minimum heights.

In planning a chimney system, it is important to know:

1. The height of a chimney is measured from the hearth to the exit point on the termination.
2. A chimney cannot be offset more than 30° from a vertical plane.
3. A chimney may run straight up or it may be necessary to offset it to avoid obstructions.
4. The maximum length of an angled run (total chimney system) is 20 feet.

5. No more than 2 offsets (4 total 30° elbows in U.S./or 2 total 45° elbows in Canada) per fireplace may be used.
6. A guy wire stabilizer is required for chimneys extending more than 6' (1.8m) above a roof line.

The Ten Foot Rule

Major U.S. building codes specify a minimum chimney height above the roof top. The "Ten Foot Rule" is a fire safety rule and not a draft rule. To ensure proper draft, it is recommended that you always meet or exceed the "Ten Foot Rule," especially when installing a termination on a high pitch roof. (Fig. 5)

The key points of the "Ten Foot Rule" are:

1. If the horizontal distance from the chimney to the peak of the roof is 10' (3m) or less, the top of the chimney must be at least 2' (610mm) above the peak of the roof, but never less than 3' (914mm) in height above the highest point where it passes through the roof.
2. If a horizontal distance from the chimney to the peak of the roof is more than 10' (3m), a chimney height reference point is established that is on the surface of the roof a distance of 10' (3m) from the chimney in a horizontal plane. The top of the chimney must be at least 2' (610mm) above the reference point, but never less than 3' (914mm) in height above the highest point where it passes through the roof.

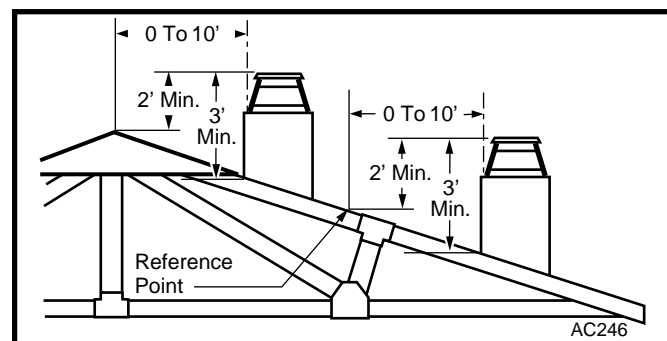

Fig. 5 Ten Foot Rule illustration.

Chimney Supports

The chimney system is supported by the fireplace for vertical chimney heights less than 30' (9m) above the hearth. Chimney supports are required if the vertical height exceeds 30' (9m). Locate chimney supports at ceiling holes or other structural framing at 30' (9m) heights. Spacing between chimney supports **must not** exceed 30' (9m). Use Chimney Support Model TCS8A. **(NOTE: The TCS8A cannot be mounted directly to the fireplace.)** Support provided by elbow straps fulfills the support requirement only if they are spaced as previously described. (A chimney support is 2½" (64mm) long when installed.)

Angled chimney runs require a support every 6' (1.8m) in addition to the elbow straps. Chimney supports are used for this function. (Fig. 6)

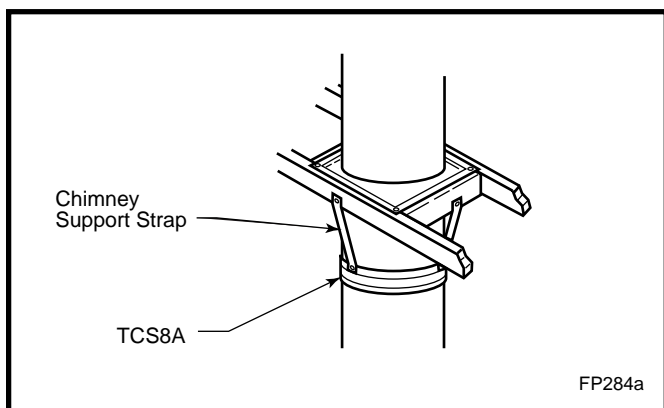

Fig. 6 Chimney support installation.

Chase Installation

A chase is a vertical box-like structure which encloses the fireplace and/or chimney. Chases are typically built on the outside of the house with fireplace opening cut into the outer wall of a room. (Page 5, Fig. 2)

If you need help in determining fireplace location or how the chimney system should be run, contact your Vermont Castings, Majestic Products dealer for assistance.

Installation

Insulating Fireplace Enclosure for Cold Climates

If you live in a cold climate, it is not required but **highly recommended** that you insulate fireplace enclosure to eliminate cold air penetration as much as possible.

Insulate base of fireplace with a noncombustible insulation rated for a minimum of 300° F. Insulating is **very important** for outside wall installations over a concrete slab. If fireplace is installed on a platform, insulation should be placed on top of the platform **before** fireplace is set. (Fig. 7)

When a fireplace is installed in a chase or on an outside wall, enclosure should be treated like any outside wall in a home. Insulation should be installed on the inside wall as well as the outside wall(s). In a chase, it is also a good idea to install a firestop at the first ceiling level above the fireplace and enclose the chase with sheeting material. Insulation may then be installed above sheeting material to assure the space around the fireplace is totally protected. (Fig. 2)

When installing the chimney, **DO NOT** caulk between outer pipe and firestop. It is vital that some air be allowed to flow through this very thin gap.

CAUTION: When installing a fireplace in an insulated enclosure, be sure all required air spaces are maintained. (Page 13, Fig. 17)

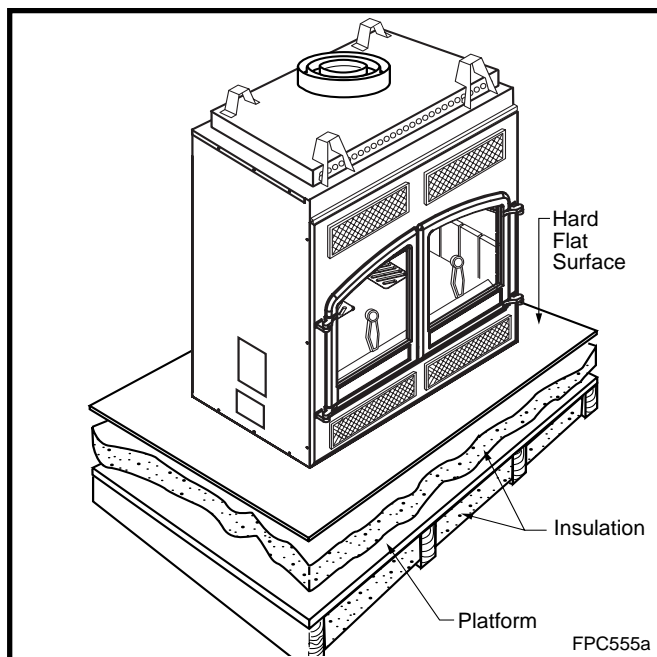

Fig. 7 Insulating between platform and fireplace.

Framing

Framing can be constructed before or after the fireplace is set in place, however, most installers build the frame before setting the fireplace.

Frame fireplace with 2 x 4 lumber or heavier materials. Refer to framing dimensions in Figure 1 for basic fireplace specifications.

NOTE: Framing should be positioned to accommodate wall covering and fireplace facing material.

EB1 (Receptacle) Hookup

Option for Circulating Models Only

Wiring should be installed by a certified electrician.

Turn off circuit breaker before wiring models.

Once fireplace is secured, complete wiring the fan kit. Remove knockout in the center of the back of the EB1 and install listed cable clamps. Feed electrical wire through listed cable clamp leaving approximately six (6) inches of wire exposed through the EB1. Secure listed cable clamp to the wire.

Attach white wire from power source to one (1) wire of receptacle and secure with nut. Attach black wire from power source to the other wire of receptacle and secure with nut. Be sure nuts are secured tightly.

Secure EB1 assembly to inside of electrical box coverplate using two screws. Attach cover to face of the EB1 while being careful to position excess wire completely within the EB1, then attach coverplate to fireplace.

Chimney Set-Up

Since you have already planned the chimney run, you should know exactly how the installation is to be accomplished - how much pipe is required, the number of elbows, if any, and type of termination to be used.

CAUTION: Report to your dealer any parts damaged in shipment, specifically check the end connection of chimney sections and elbows.

NOTE: The EWF36A fireplace must use Vermont Castings, Majestic Products model triple wall 8" chimney components only. The installation procedure described in this manual applies only to this system.

Straight-Up Chimney Installation

To mark the centerline of the flue, put the fireplace in final position and measure out from the wall: 9½" (241mm). Mark a spot on the ceiling directly above the fireplace. Draw a line parallel to the back wall through this mark. (Fig. 8)

Using a plumb bob positioned directly over center point of fireplace flue collar, mark the ceiling to establish the chimney center point. (Fig. 8)

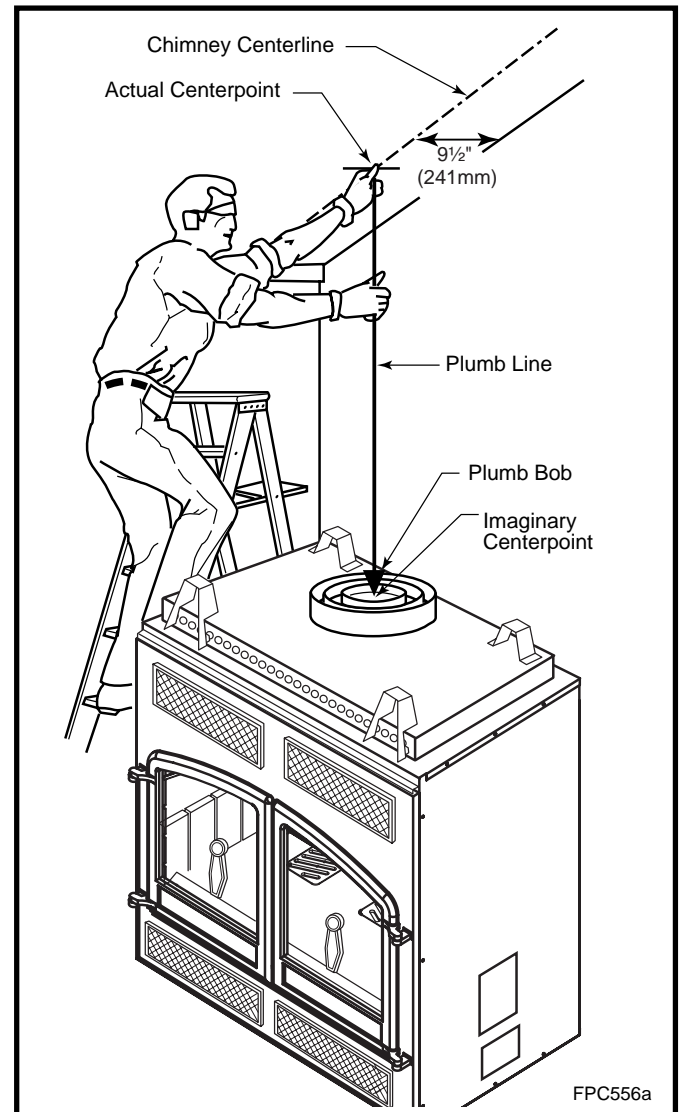

Fig. 8 Locate centerline of chimney with plumb line.

Offset Installation

In order to clear an obstruction, it may be necessary to offset chimney from vertical. This is accomplished by using elbows. Use the 30° Offset Elbow table on Page 6 to determine proper offset and parts required.

Each offset requires two (2) elbows. The second elbow is equipped with support straps. It is very important to install the second elbow in each offset as close to the ceiling or support as possible so that the elbow straps can be secured to framing members to help support the weight of the chimney.

Determine offset distance of your chimney arrangement from centerline of fireplace to centerline of chimney where it is to pass through ceiling.

Locate center point of the chimney on ceiling as though a straight up chimney arrangement is to be used. Measure your offset dimension from straight up chimney center point on ceiling.

Ceiling Chimney Hole/ Possible Obstructions

The size of the hole in ceiling will vary with the angle at which the chimney passes through ceiling.

Drive a nail up through ceiling at marked chimney center point. Go to floor above and see where hole will be cut. Check to see where existing ceiling joists and other possible obstructions are located...i.e. wiring, plumbing etc... If necessary, re-position chimney and/or fireplace to avoid obstructions.

Cutting the Hole

Cover fireplace collar opening and cut proper sized chimney hole in chimney.

Framing the Ceiling Hole

Frame the ceiling chimney hole as shown in Figure 10. It is good practice to use framing lumber that is the same size as the ceiling joists; this is a requirement at attic level.

The following table gives firestop spacer model numbers:

Chimney Hole Size		
Size of Chimney	Angle of Chimney at Ceiling	
	Vertical	30°
8" Flue	FS2A 17½" x 17½" (445 x 445mm)	FS6A 17⅞" x 29⅝" (454 x 753mm)

Fig. 9 Ceiling chimney hole sizes necessary for installing firestop spacer.

The **inside dimension** of the frame **must be** the same as the hole size selected from Figure 9 in order to provide required the 2" (51mm) air space between the outside diameter of the chimney and the edges of the framed ceiling hole.

Positioning, Safety Strips, Securing the Fireplace

Slide fireplace into position.

Safety strips are used to ensure that any combustible materials in front of the fireplace are protected even though a noncombustible hearth extension is required.

When the finished extended hearth is added, the top of the finished hearth must be flush with the bottom of the fireplace. "Z" shaped metal safety strips have been

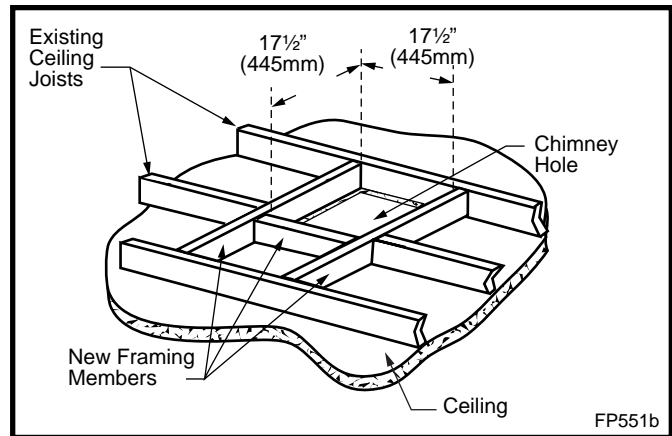

Fig. 10 Typical frame for ceiling chimney hole.

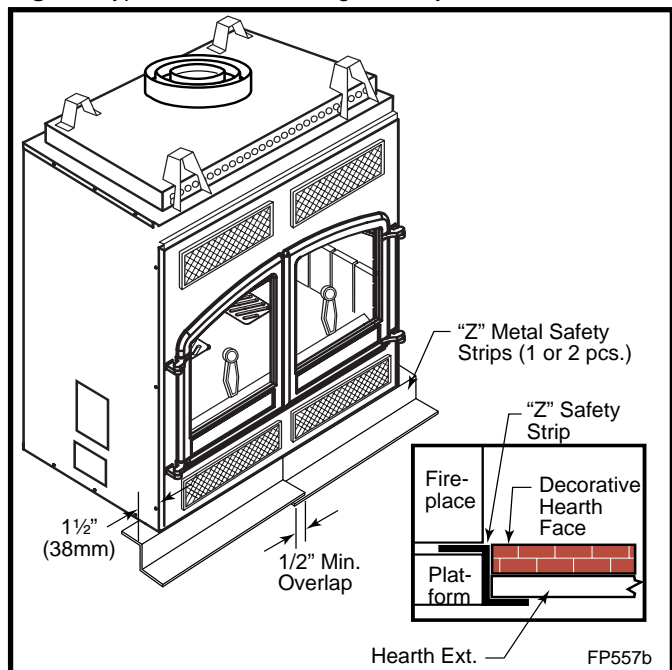

Fig. 11 Safety strip installation.

supplied with the fireplace and are required for installation. The safety strips provided have a 1" offset. For applications with a greater offset, "Z" shaped strips will have to be fabricated of metal. Overlap safety strips at least 1/2" to provide a positive joint. The safety strips must also extend at least 1 1/2" (38mm) beyond the sides of the fireplace. (Fig. 11)

NOTE: Safety strips are not required over noncombustible floors where all supports at the base of the fireplace are noncombustible.

Four (4) nailing flanges are supplied with the fireplace (found on the fireplace hearth). To level the box and secure it firmly in place, remove the nailing flanges from the hearth and install at the sides of the fireplace as shown in Figure 12.

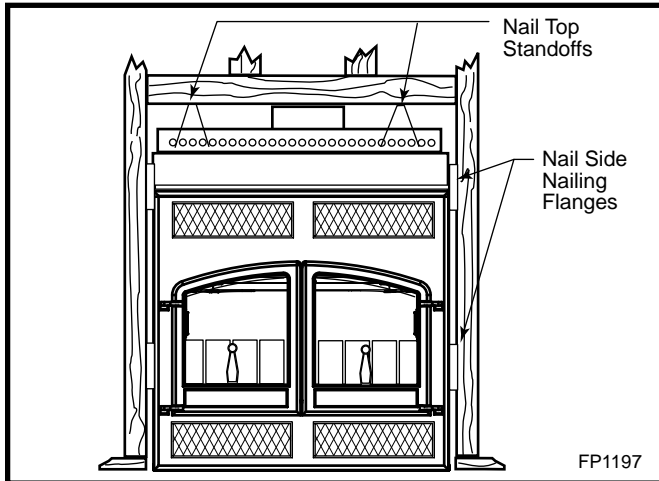

Fig. 12 Fasten fireplace in position.

Installing Outside Air Kit

An outside air kit may be installed on the EWF36A. If desired, or if local codes mandate the use of an air kit, then two (2) AK-MSTs are required to complete the installation (from air kit to the outdoors). If the outside air kits are to be used, the AK-MSTs MUST be installed BEFORE the fireplace is enclosed.

NOTE: Four (4) inch Class 1 air duct, material or metal duct (not supplied) may be used with AK-MST. **(For installation in New York State, only aluminum, noncombustible flexible or type "O" metal ducting is permissible.)**

Installation Precautions

The duct termination should be located so it is exposed to an out-of-doors opening at least 100 square inches. If the duct termination must be located in a crawl space or basement, be sure the termination area has 100 square inches of ventilation opening to outside air.

The duct termination must be located so it does not compete for air flow with exhaust fans, gas vent hoods or other air consuming devices or appliances. It must not be obstructed by rafters, insulation materials or other obstructions. The less restrictive the air supply, the better the AK-MST will perform.

It is a good practice to protect your hands and eyes during installation by wearing work gloves and safety glasses.

CAUTION: Do not install termination into a garage or other area that could contain flammable liquids or fumes, or into an attic space.

Installation Instructions

Determine the location of the fireplace as described in the fireplace Installation Manual. Then plan location of the duct termination and the route of the duct run between the fireplace and the duct termination.

Duct run must be limited to a maximum distance of 40 feet from the fireplace pipe collar to duct termination. This will provide the least restriction to air flow. No more than four (4) 90° elbows can be used. Duct run may be horizontal, vertical, inclined or any combination of these. Vertical duct runs must be at least three (3) feet below the fireplace chimney flue exit. (Fig. 13) You are now ready to install the AK-MST Outside Air Kit.

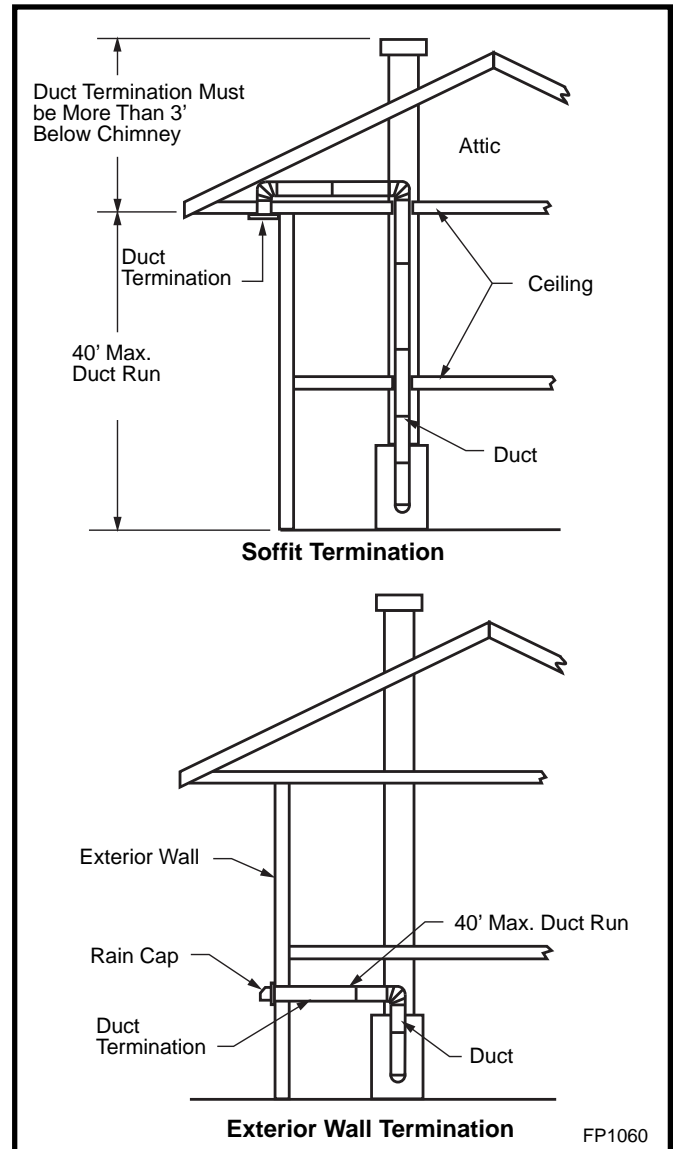

Fig. 13 Typical installations.

1. Remove and discard the outside air cover plate located at the center of both sides of the fireplace. Use care not to rub against the sharp edges of this opening to avoid cuts. Remove the four (4) screws exposed when cover plate is removed. Retain for future use.
2. Slide the two (2) connecting boxes provided with the unit into the openings on each side of the unit.
3. Attach the connecting boxes to the inside panel with four (4) screws removed in Step 1.

4. Attach the inlet collar with four (4) #10 screws to the side near the bottom of the fireplace. Slide the duct over the collar and attach the duct to the collar using the plastic tie straps or three (3) screws (screws not provided). Continue attaching the ducting together using three (3) screws at each joint until you have installed sufficient duct to arrive at your duct termination location.
5. At the termination end, install the duct termination. This should be installed from the outside of the home. Cut a hole in the desired location approximately 4½" in diameter, caulk around the hole, and slide the termination through the opening from outside the home. The termination/rain cap should be caulked around its perimeter to assure a tight seal. The rain cap opening should be positioned downward. (Fig. 14)

The AK-MST Outside Air Kit is now installed and ready for use.

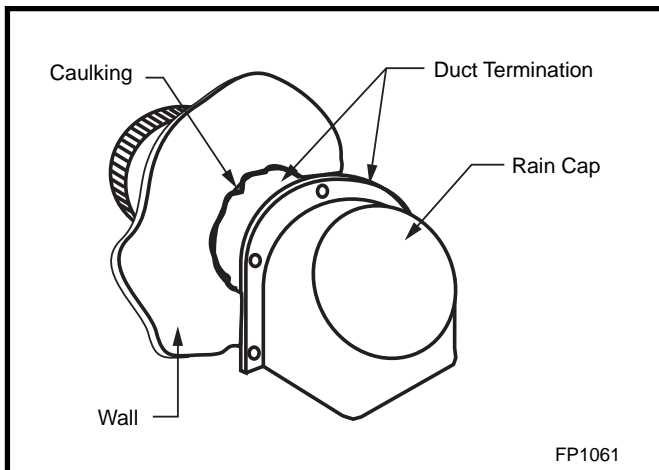

Fig. 14 Caulk and install duct termination/rain cap in place.

Installing the Chimney System

Start by attaching the first chimney section to the collar on top of the fireplace.

Install the pipe as pictured in Figure 15. When you get a good lock, you will hear the pipe clearly snap together. Once sections are snap-locked in place, it is extremely difficult to get them apart. **Make sure the pipe is firmly snapped and locked together as each pipe section is mounted.**

When installing elbows, only outer pipe will snap-lock. Middle pipes simply slide into position. Be sure to always attach straps on upper elbow to a structural framing member. (Fig. 16)

Continue installing the pipe as required until pipe is installed up through the ceiling. At this point, you must install a firestop spacer.

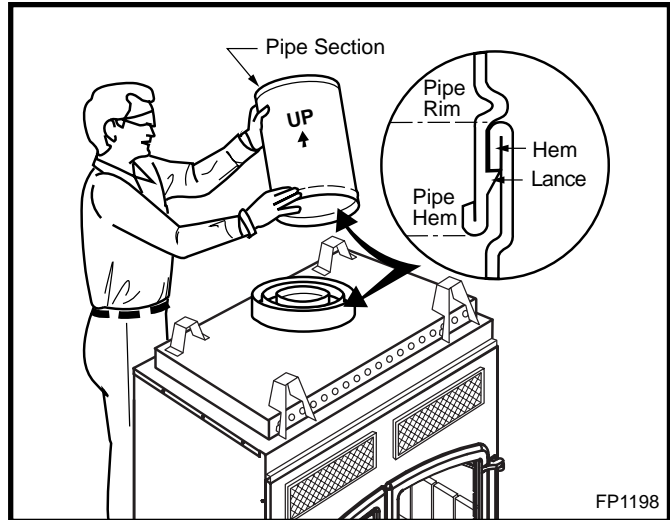

Fig. 15 Install pipe, listening for the snap-lock to fasten.

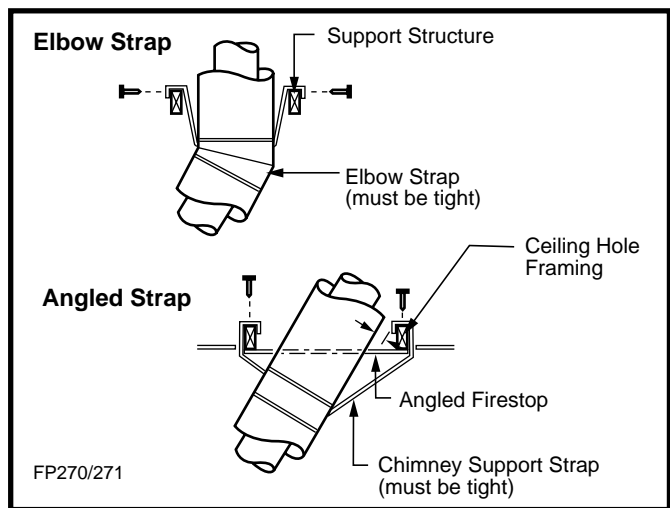

Fig. 16 Attach straps to a structural framing member.

Installing the Firestop Spacer in the Ceiling Hole

A firestop spacer is used to keep pipe spaced properly and required for safety.

Nail the firestop spacer (at each corner) to the framing members of the ceiling hole. **NOTE:** A firestop spacer is not required at the roof.

Hole sizes listed in Figure 9 for angled firestop spacers provide minimum required air space to chimney pipe for ceiling thickness up to 8" (203mm). When combined thickness of ceiling material, ceiling joists and flooring material exceeds 8" (203mm), adjustments must be made in framing to assure that minimum air spaces to chimney are maintained.

Proper Firestop Spacer Installation

Figure 17 shows different installation procedures for both an area that is an attic and an area that is not an attic.

If the area above the ceiling **is not** an attic, position the firestop spacer with the flange on the ceiling side and the angled portion extending up into the hole.

If the area above the ceiling **is** an attic, position the firestop spacer with the flange on the top of the framed hole and the angled portion extending down into the hole.

Firestop spacers are not available for, nor are they required on vertical walls.

DO NOT put any sealant around the area where the outer pipe slides through the firestop spacer. If you seal this area, **it may cause a fire hazard.**

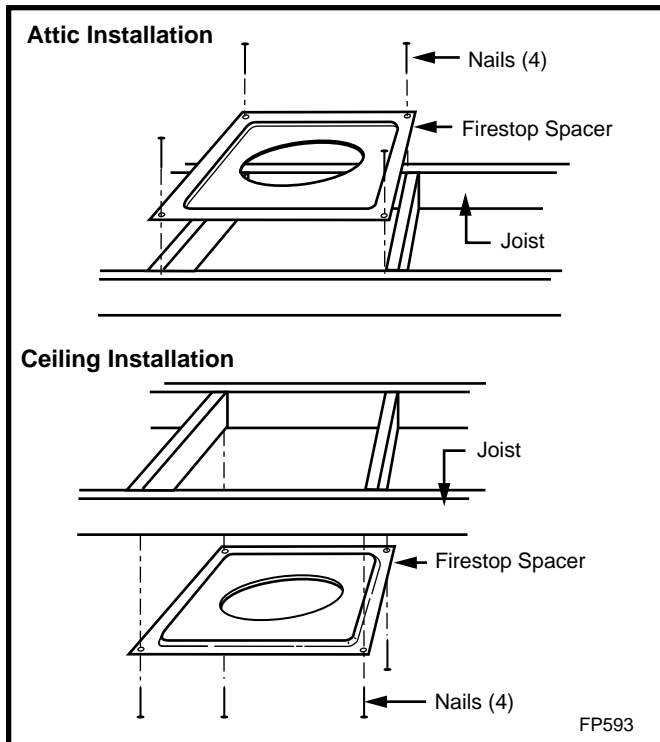

Fig. 17 Firestop spacer installations.

Canadian Requirements for Insulation Shield

In Canada, an attic insulation shield is required to prevent attic insulation from contacting the chimney section. Framing dimensions for the chimney hole should measure 17½" x 17½" (445mm x 445mm). An attic shield **MUST** be installed on top of attic joists (above the floor level). (Fig. 18)

Continue Installing Pipe to Complete Run

Continue attaching pipe sections to complete system to next level always being careful that the pipe is firmly snapped locked in place before proceeding to next pipe section.

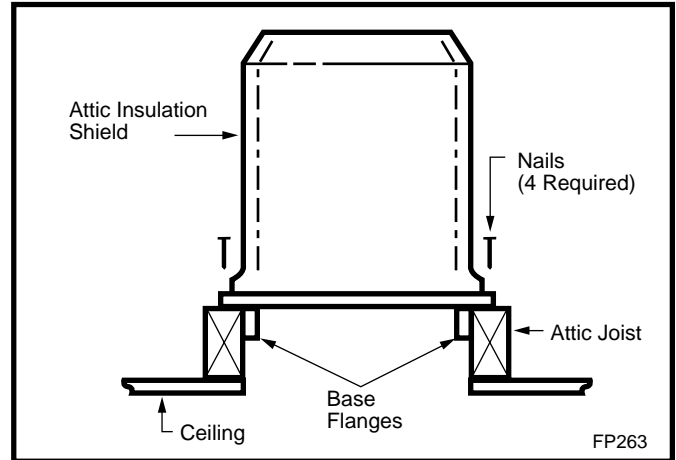

Fig. 18 Attic shield installation (Canadian requirement).

Chimney Supports

If chimney supports are required, they are installed the same as elbows. Nail chimney support straps to adjacent structural framing, as shown on Figure 16. Bend straps as necessary and make sure they are secure so they will support the weight of the chimney. A chimney support is 2½" (64mm) long when installed. Consider this dimension when determining how many straight chimney sections are needed.

NOTE: Chimney supports are generally used in long runs in a chase installation.

Additional Ceilings

If you encounter additional ceilings, repeat same steps required for first ceiling installation. See firestop illustration in Figure 17.

Penetrating the Roof

Run pipe to roofline. Since chimney system must be vented to the out-of-doors, you **must** use an approved Vermont Castings, Majestic Products termination.

If a chase is used, refer to the installation manual provided with the termination cap.

Locate Chimney Centerpoint on Roof

Use same procedure detailed in locating center point of the flue system.

Drive a nail up through roof at the center point. This will determine center point on outside of the roof.

Cut and Frame Roof Hole

Size of roof hole varies with the type of chimney termination installed. Refer to installation instructions provided with Vermont Castings, Majestic Products chimney termination to find correct size of roof hole.

There must be a 2" (51mm) air space between outermost portion of chimney sections and any adjacent combustible surfaces. (Combustible surfaces include burnable materials such as: ceiling members, joists, flooring, combustible insulation and roof structures.)

WARNING: Do not pack required air spaces with insulation or other materials.

Mark an outline of the roof hole around the center of the point nail. **NOTE:** Hole dimensions given in the chimney top installation instructions are **horizontal** dimensions; therefore, the hole size must be marked on the roof accordingly.

Cover the opening of the installed chimney so debris cannot get into the system.

Cut and frame the hole. It is good practice to use framing lumber that is the same size as the rafters. Install the frame securely because the chimney top and flashing anchored to the frame must be able to withstand heavy winds.

Install Remainder of Chimney Sections

Since you have already preplanned the height of your termination according to the *Ten Foot Rule*, continue to install pipe to the predetermined height.

Check the chimney top installation instructions for details on how high above the roof top the chimney sections (all pipes) should extend.

Install Top Housing or Termination

Follow the installation instructions provided with the Vermont Castings, Majestic Products chimney termination you have selected.

Installing Chimney in a Chase

Refer to Figure 2, Page 5 for an illustration of a typical chase installation.

CAUTION: Treatment of firestop spacers and construction of chase may vary with type of building. These instructions are not a substitute for local building codes. You **must** check your local building codes to determine specific requirements for your city or state. **NOTE:** Other building materials may be required in addition to Vermont Castings, Majestic Products Firestop Spacers.

Finishing

CAUTION: All joints between the finished wall and the fireplace surround (steel front) must be sealed with noncombustible material to prevent cold air leakage into the room. (Fig. 19)

NOTE: No material may cover black cast face.

Finish Wall

Finish the wall with material of your choice. **Do not install a combustible mantel shelf less than 12" (305mm) above the firebox grille opening. Do not install a mantel face plate less than 6" (159mm) from top of grille opening. (Fig. 21)** If a combustible material is used below a flat mantel shelf, consult your local building codes for minimum clearance from top of fireplace opening to bottom of mantel shelf.

All joints (top, bottom and sides) where wall or decorative facing material meets fireplace surround must be completely sealed with a noncombustible material. (Figures 20 and 24)

NOTE: No side wall protection is required for fireplaces installed at 45° to two (2) side walls (corner installation).

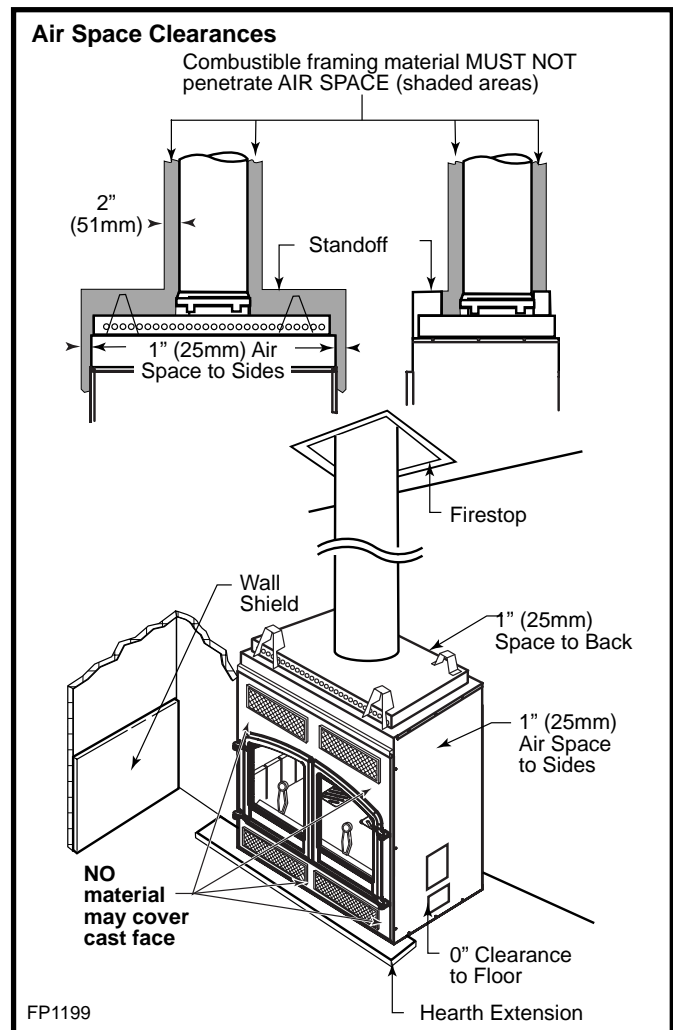

Fig. 19 Minimum clearances to combustibles.

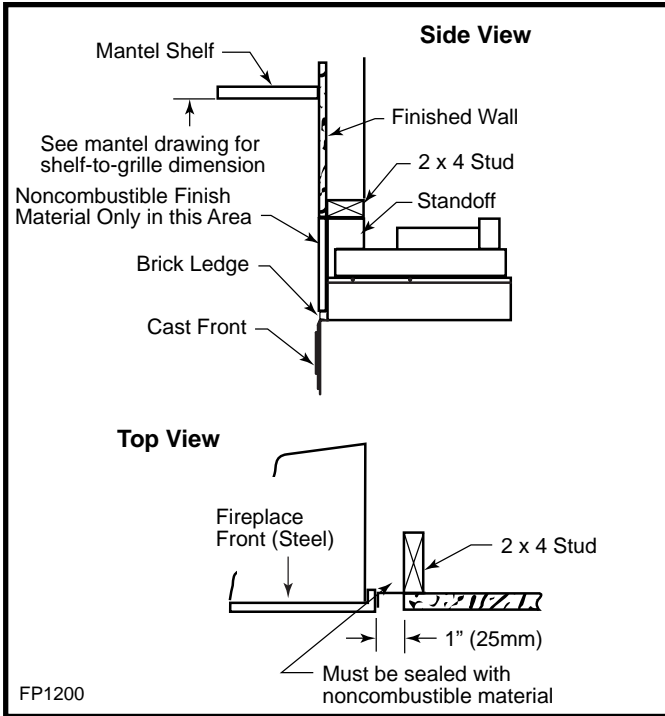

Fig. 20 Finishing materials placement.

Mantels

The height that a combustible mantel is fitted above the fireplace is dependent on the depth of the mantel. This also applies to the distance between the mantel leg (if fitted) and the fireplace.

For the correct mounting heights and widths, refer to Figures 21 and 22. When using paint or lacquer to finish the mantel, such paint or lacquer must be heat resistant to prevent discoloration.

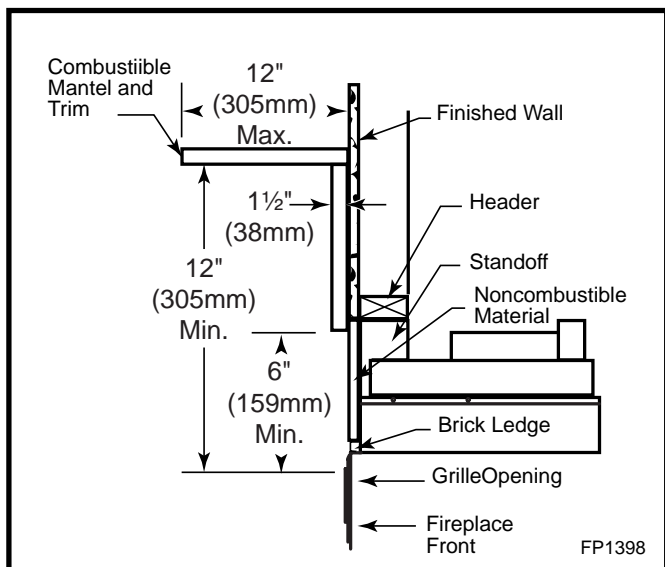

Fig. 21 Combustible mantel minimum opening.

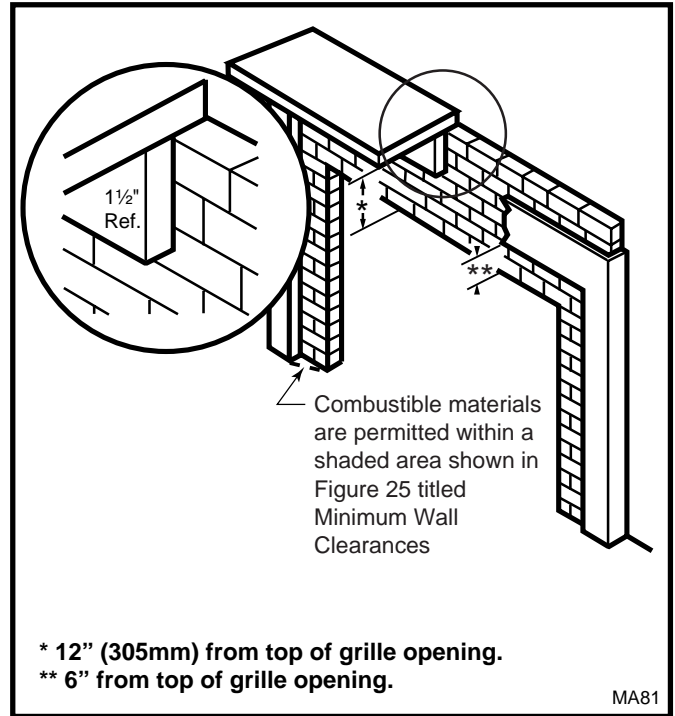

Fig. 22 Combustible mantel clearances.

Side Wall Protection

Adjacent combustible side walls that are within minimum dimensions shown in Figure 24 of the fireplace opening must be protected with Majestic Wall Shield Model SP40 or a specifically built wall shield described in Figure 19.

The special wall shield design described in Figure 19 is an alternate method of adding protection to side walls and can be used in place of the SP40 with the same wall clearances specified for the SP40. Rt must = 1.85 minimum.

Examples of wall shield insulation:

1. Manville - CERAFORM 126, K=.27, 1/2 inches thick
2. EH2416, K = .458, 1 inch thick required.

Hearth Installation

A hearth extension is required to protect a combustible floor in front of the fireplace. Refer to Figure 25 for minimum dimensions and mounting detail.

NOTE: Hearth Extension must not cover the air inlet opening of a fireplace.

The hearth extension described in Figure 25 must be a durable noncombustible material with a minimum (total) Rt value of 1.09; see Figure 23 for examples. The overall height (above a combustible floor), depth and width must be as indicated, with the extension centered to the fireplace opening.

The top of insulation must be covered with a non-combustible decorative covering **or** a piece of .018" minimum sheet metal, to protect hearth extension material. (Fig. 25)

Secure the hearth extension to the floor to prevent shifting, using trim molding or other similar means at three (3) outer edges. Seal crack between the fireplace hearth and hearth extension with a noncombustible material. (Figs. 24 and 25)

WARNING: Hearth extension must be installed in accordance with Figure 24. Top of hearth extension must be level with bottom of fireplace.

Alternate noncombustible materials may be used providing the (total) thermal resistance (Rt value) of the alternate material employed is greater than or equal to $R = 1.09$ Thermal resistance (R) or thermal conductivity (K), may be obtained from manufacturer of the material. Factors are related by the formula $K = 1/R$. (Fig. 23)

T = given thickness

R = thermal resistance for a given thickness (T)

K = thermal conductivity

Noncombustible material with a lower R value may be used, provided thickness of material is sufficiently greater to maintain an equivalent (total) thermal resistance (Rt).

COMMON MATERIALS AND FACTORS			
MATERIAL	K*	R	MINIMUM THICKNESS
EH2416 <i>(Majestic Products Company)</i>	0.916	2.18	1.0 in.**
Common Brick	5.0	0.10	5.46 in.**
R Value is for 1/2 inch. * Units of K = BTU/SQ FT/HR/3F/IN ** Thickness of Listed Material			

FP533ADD

Fig. 23 Hearth extension material factors.

Example of Determining Hearth Extension Equivalents

To determine the thickness required for any **new** material:

$$\text{NEW required thickness} = \frac{\text{K of new material (per inch)} \times \text{thickness of listed material}}{\text{K of listed material (per inch)}}$$

Example for Common Brick

$T(\text{new}) = 5.0/0.458 \times 0.50 \text{ in.} = 5.46 \text{ in.}$ (new required thickness).

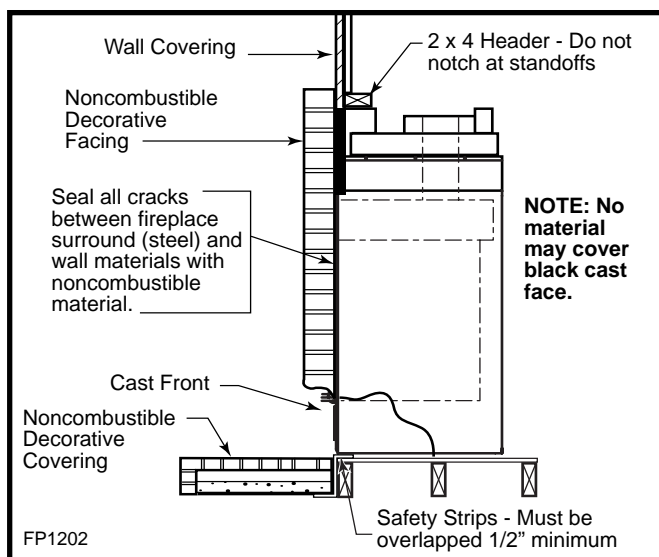

Fig. 24 Sealing gaps.

Operation

Attach Handles

The fallaway handles are used to open and close the front doors. Remove after each use so they will not get hot. Keep in convenient location for each use. (Fig. 26)

Assemble the primary air control and damper handles by passing the 3/8" screw through the ceramic shaft and into the bright metal hub. Tighten carefully until snug. Do not overtighten. Ceramic handle could crack. (Fig. 27)

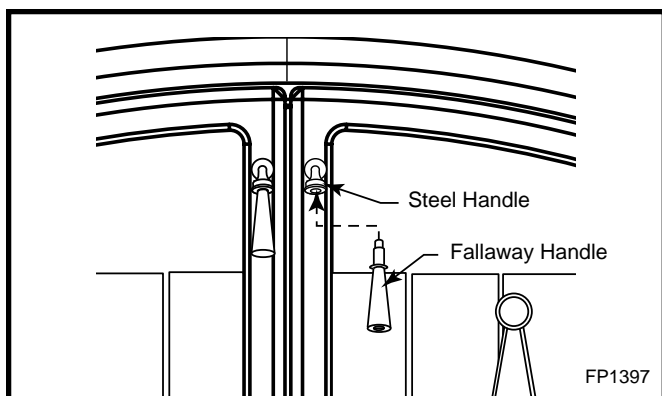

Fig. 26 Insert fallaway handles into door handle stubs.

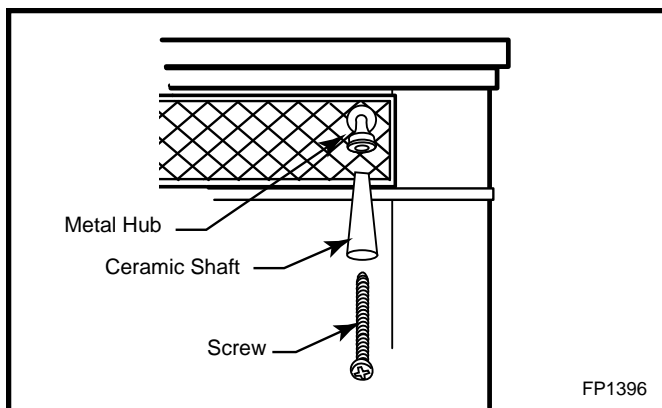

Fig. 27 Assemble primary air control and damper handles.

EWF36A Controls

Three controls regulate the performance of the EWF36A fireplace: A primary air control supplies oxygen for the fire, the damper directs air flow within the fireplace and a variable-speed fan control, or rheostat, regulates the warm air flow into the room. (Fig. 28)

Primary Air Control

A single air control regulates the amount of heat the fire will produce and how long it will burn.

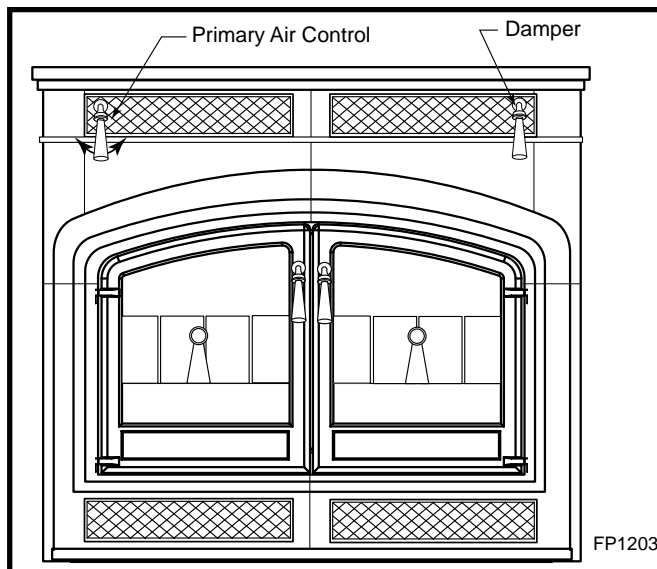

Fig. 28 EWF36A controls.

The **primary air control** is located in the upper left corner of the unit. (Fig. 26) It is the primary source of air for starting, maintaining, and reviving the fire.

Generally, more air entering the fireplace makes the fire burn hotter and faster, while less air prolongs the burn.

The air supply is open to the maximum when the control lever is rotated clockwise, and closed when rotated counterclockwise. To vary the burn rate, adjust the control to the desired position in between these extremes; opening the primary air control makes the unit burn hotter. Closing the control slows the unit down. You may adjust to any position you desire.

The Damper

The damper directs air flow within the fireplace.

The **damper** is operated by moving the lever located in the upper right corner of the unit. It has two positions: Open to start or revive the fire and closed, for normal operation and to control burn rate. The damper is open when the lever is fully rotated counterclockwise and pulled out and closed when pushed in. When the damper is in the open position, with the lever pulled out, and rotated fully in the clockwise direction, the handle can 'telescope' back without closing the damper or any damper movement. There are no intermediate settings for the damper.

NOTE: Full clockwise or counterclockwise movement of the damper handle is approximately 50°.

NOTE: Always open the damper before opening the doors. Close damper to set burn rate.

The Fan

Heated air from the fireplace is forced into the room by an internal fan. The control for the fan is in the right corner of the unit.

“Off” is to the far left.

“High” is just to the right of “Off.”

“Low” is to the far right.

Variable adjustment of the fans is possible with any setting between “high” and “low.”

For best results, coordinate fan speed with the setting of the primary air control. For example, when the air control lever is set at “low,” also set the fan at “low.”

With the air control set for maximum heat, set the fan at “high.”

Glass Doors

The EWF36A is intended for use with the doors fully closed or fully open only when optional spark screen is installed. (Fig. 29) **NOTE: When operated with the doors open and spark screen in place, the damper MUST be in the open position.**

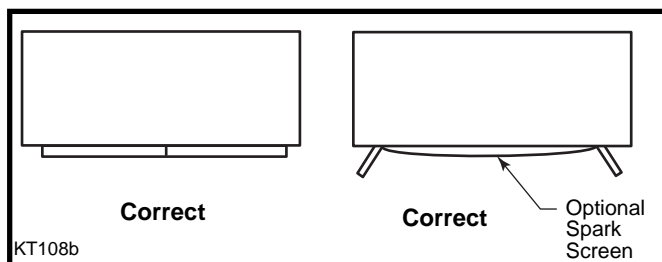

Fig. 29 Correct door position during operation.

Burn Only High-Quality Wood

The EWF36A is designed to burn natural wood only; do not burn fuels other than that for which it was designed.

You will enjoy the best results when burning wood that has been adequately air-dried. Avoid burning “green” wood that has not been properly seasoned.

The best hardwood fuels include oak, maple, beech, ash, and hickory that has been split, stacked, and air-dried outside under cover for at least one year.

For areas that do not have a supply of hardwood, commonly burned softwoods include tamarack, yellow pine, white pine, Eastern red cedar, fir, and redwood. These too should be properly dried. Your EWF36A will accept wood up to 24" (610 mm). Longer wood pieces work better than short ones.

Wood should be stored under cover to maintain dryness, and should be dried at least six months for optimum heating and fire-viewing performance. Even

for short-term storage, however, keep wood a safe distance from the heater and keep it out of the areas around the heater used for refueling and ash removal.

Use the Air Control Settings that Work Best for You

No single air control setting will fit every situation. Each installation will differ depending on the quality of the fuel, the amount of heat desired, and how long you wish the fire to burn.

The control setting also depends on your particular installation’s “draft,” or the force that moves air from the stove up through the chimney. Draft is affected by such things as the length, type, and location of the chimney, local geography, nearby obstructions, and other factors.

Too much draft may cause excessive temperatures in the fireplace. On the other hand, too little draft can cause backpuffing into the room and/or the “plugging” of the chimney or combustor.

How do you know if your draft is excessively high or low? Symptoms of too much draft include an uncontrollable burn or a glowing-red part of the EWF36A front. A sign of inadequate draft is smoke leaking into the room through the stove or chimney connector joints, low heat, and dirty glass.

In some newer homes that are well-insulated and weather-tight, poor draft may result from insufficient air in the house. In such instances, an open window near the stove on the windward side of the house will provide the fresh air needed.

Another option for getting more combustion air to the stove is to duct air directly from the outside to the stove. In fact, in some areas provisions for outside combustion air are required in all new construction.

Your EWF36A is designed so that it is possible to incorporate outside air for combustion. Directions for installing the optional AK-MST outside air ducts are included with the kits and beginning on Page 11 of this instruction.

When first using the stove, keep track of the settings of the air controls. You will quickly find that a specific setting will give you a fixed amount of heat. It may take a week or two to determine the amount of heat and the length of burn you should expect from various settings.

Most installations do not require a large amount of combustion air, especially if adequate draft is available. **Do not for any reason attempt to increase the firing of your heater by altering the air control adjustment range outlined in these directions.**

Starting and Maintaining a Wood Fire

Burn solid wood fuel only in the EWF36A, and burn it directly on the grate. Do not elevate the fuel. Do not burn coal or other fuels.

Minimize thermal stress by allowing the plates to adjust gradually during an initial break-in fire by following Steps 1-3 below.

WARNING: Operate your EWF36A only with the doors fully closed. If the door is left partially open, gas and flame may be drawn out of the fireplace opening, creating risks of both fire and smoke.

1. Open the primary air control fully.
2. Open the damper.
3. Lay some crumpled newspapers on the bottom grate. Place on the paper six or eight pieces of dry, finely-split kindling. On the kindling lay two or three larger sticks of split dry wood approximately 1-2" (25-50 mm).

Do not use chemicals or fluids to start the fire. Do not burn garbage or flammable fluids such as gasoline, naphtha, or engine oil.

Also, never use gasoline-type lantern fuel, kerosene, charcoal lighter fluid, or similar liquids to start or "freshen up" a fire in this heater. Keep all such liquids well away from the heater while it is in use.

4. Light the newspaper and close the door. Gradually build up the fire by adding a few 3-5" (80-120mm) diameter splits.

If this is your initial break-in fire, let the fire burn brightly, but not to excess. Control the fire's intensity by adjusting the air control lever. After an hour or so stop adding wood so that the fire dies out gradually.

For ongoing operation after the initial break-in, continue to add a few sticks at a time of a progressively larger size. Continue until you have a live ember bed at least 2-3" (51-76mm) deep. This may take an hour or longer.

CAUTION: THE EWF36A IS HOT WHILE IN OPERATION! KEEP CHILDREN, CLOTHING, AND FURNITURE AWAY. CONTACT MAY CAUSE SKIN BURNS.

NOTE: Some chimneys need to be "primed," or warmed up, before they will draw sufficiently to open the damper. To correct this situation, roll up a couple pieces of newspaper, place them on top of the kindling and toward the back of the stove, light them, and close the doors. This should heat the chimney enough to initiate a draft.

Once the draft is established, open the front door and light the rest of the fuel from the bottom. Do not light the main bed of fuel until the chimney begins drawing, and repeat the procedure as often as necessary if the initial attempt is unsuccessful.

5. Once a good ember bed of at least 2-3" (51-76 mm) has formed, let the fire burn hot for an additional ten to fifteen minutes.
6. Close the damper and the primary air control to a medium-low setting as described on Page 18. The fire volume will diminish immediately, but the fireplace will continue to heat up. Maintain control of the fire using the primary air control, and remember: reduce the setting for less heat, increase the setting for more heat. Refer to the air control settings information on Page 18 for recommended settings at different burn rates.

DO NOT OVERFIRE THIS HEATER. Overfiring may cause a house fire, or can result in permanent damage to the stove. If an exterior part of the EWF36A glows, you are overfiring.

Reloading and Reviving a Wood Fire

- Open the damper and set the air control on "High," and wait at least fifteen seconds for the draft to increase. Open the door slowly.
- Check the ash level, and empty the ash pan if necessary. Replace the pan.
- Add the fuel, smaller pieces first. If it is necessary to use wood smaller than the 24" (610mm) optimum size, be sure to fill the firebox as completely as possible by loading the wood pieces alternately on the left and right. Split wood will fill the firebox more completely and reduce the frequency of reloading.

If you have an ember bed of at least 2-3" (51-76 mm), leave the thermostat set on "high" for 10-15 minutes. If the ember bed is less than 2-3" (51-76mm), you may have to let it burn longer.

Finally, close the damper and adjust the air control and fan speed for your desired heat level.

NOTE: If the charcoal bed is relatively thick and your fuel is well-seasoned, it is possible to add fresh fuel (smaller pieces first), close the door and damper, and reset the air control within five minutes.

Special Tactics for Cold-Climate Heating

The EWF36A is capable of producing in excess of 100,000 Btu's/hour and heating an area of up to 2,500 sq. ft. (558 sq. m) However, many factors affect heating performance and can influence the extent to which the EWF36A can heat a given area.

A well-insulated home, located in a moderate climate and with the EWF36A Fireplace located centrally in an open floor plan, will be easier to heat than a drafty home in the far north in which the EWF36A is installed on an exterior wall at the end of a long house.

Different results may be experienced even in the same installation if you switch from burning good, dry wood to wood that is partially rotted or inadequately seasoned.

To compensate for these factors in cold climates, it may be necessary to operate the EWF36A with the air control set to a higher level more of the time.

Remove and Store Ash Safely

Check the ash pan before reloading the stove, and empty if necessary using the following procedure:

- Open the damper.
- Open the load door.
- Remove the ash pans from under the hearth brick. The EWF comes with a cover for the ash pan. To install this cover, hold just above the ash pans with the handle on the cover closest to you. Slide the cover onto the top of the pan as you pull the pan out. As the pan slides out, the flange on the back of the cover should slide into the slot in the back of the ash pan and the flange on the front of the cover will slide over the handle on the ash pan. **CAUTION:** Do not pull the pan out too far before the cover engages the slot. Ash may contain hot coals and must be treated with extreme care. Hold the covered ash pan with both hands to avoid dropping or spilling the ashes.
- Take the pans outdoors and empty the ash into an ash container.
- Before replacing the ash pan, clear away any ash that has spilled over the sides and back of the pan.
- Replace the ash pans and front door.

Empty the ash pans regularly, typically every one to three days. The frequency will vary depending on how you operate your EWF36A: If you burn more wood at higher heat output settings, and ash will accumulate faster.

Ash should be removed frequently and placed outdoors in a metal container with a tight-fitting lid. The closed container of ash should be placed on a noncombustible floor or on the ground, well away from all combustible materials, pending final disposal. If the ash is disposed of by burial in soil or otherwise locally dispersed, it should be retained in the closed container until all cinders have thoroughly cooled. Wood ash may be used as a garden fertilizer.

CAUTION: Never use your household or shop vacuum cleaner to remove ash from the fireplace; always remove and dispose of the ash properly.

Maintenance

Keep your EWF36A Fireplace Looking New and Working Its Best

Care of the Cast Iron Surface

An occasional dusting with a dry rag will keep the painted cast iron of your EWF36A fireplace looking new.

If the paint needs retouching, first allow the surface to cool completely. Wire-brush areas needing to be painted. Touch-up with high temperature stove paint available from your local dealer. Apply the paint sparingly. Two light coats are better than one heavy one.

Cleaning the Glass

The EWF36A glass system requires a minimum amount of cleaning. Most carbon deposits that accumulate will burn off during hot fires.

Ash residue that accumulates on the glass should be removed periodically to prevent etching. To clean the glass, follow this procedure:

- Be sure the glass is completely cool.
- Cleaning with water will work in most cases. Use a glass cleaner especially made for this purpose only if deposits are especially heavy. (If heavy deposits are a frequent occurrence, however, evaluate your operating techniques.)
- Rinse the glass thoroughly.
- Dry the glass completely.

NOTE: The EWF36A glass is coated with a special material on the outside that helps reflect heat back into the fire chamber. Do not attempt to remove this coating.

Adjust the Door Latch Periodically

The front door of the fireplace should close securely to prevent accidental opening and should close tightly to prevent air from leaking into the fire chamber. The door handles will be positioned vertically when the door is closed.

Over a period of time, the gasket around the door will compress and the latch may need adjustment. To adjust the handle, follow this procedure (Fig. 30):

1. Loosen the small lock nut with a wrench.
2. Extend the striker screw one turn by turning it with an Allen wrench.
3. Retighten the lock nut, while at the same time holding the striker screw with the Allen wrench to prevent its turning.

Test the door seal. Close the door on a dollar bill and attempt to pull it free. If the bill is freed with little

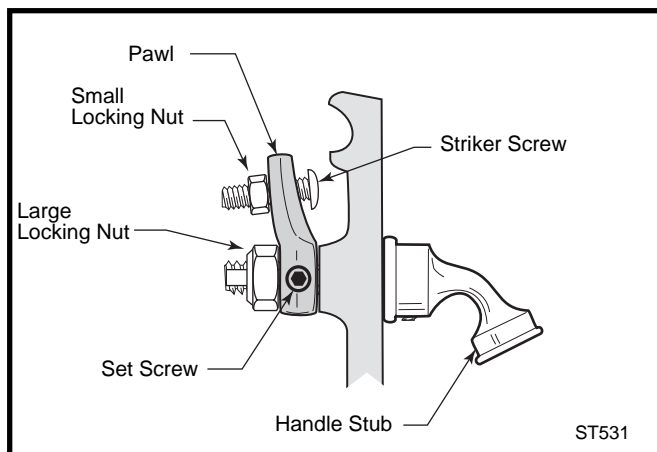

Fig. 30 Turn the striker screw to tighten or loosen the door latch.

resistance, the gasket isn't snug enough at that spot. Continue to make small adjustments until the setting is right.

If additional adjusting of the latch does not enable the door to seal sufficiently in one area, try "adjusting" the gasket in that area. Pack more cement or a smaller diameter gasket into the channel beneath the gasket so that the main gasket is raised and makes contact with the door frame. This procedure should solve the problem. If the gasket needs replacing, follow the directions beginning on Page 23.

The Catalytic Element

This wood heater contains a catalytic combustor, which needs periodic inspection and replacement for proper operation. In the United States, it is against the law to operate this wood heater in a manner inconsistent with the operating instructions in this manual, or if the catalytic element is deactivated or removed.

Under normal operating conditions, the catalytic combustor should remain active for two to six years (depending on the amount of wood burned). However, it is important to monitor the combustor periodically to ensure that it is functioning properly, as well as to determine when it needs to be replaced. A nonfunctional combustor will result in a loss of heating efficiency, and an increase in creosote and emissions.

Inspection and Cleaning

Inspect the combustor "in place" for fly ash accumulation and physical damage three times per year. Do not remove the combustor unless a more detailed inspection is warranted because of diminished performances as outlined in the next section.

When to Suspect a Combustor Problem

The best way to evaluate the performance of your EWF36A's combustor is to observe the amount of smoke leaving the chimney - both when the combustor has "lighted-off" and when it has not. Follow these steps:

- With a fire going and the combustor properly activated, with the damper closed to route smoke through it as described in the Operation Section, go outside and observe the smoke leaving the chimney.
- Then, open the stove damper and once again check the smoke leaving the chimney.

You should see significantly more smoke when the stove damper is open and exhaust does not pass through the combustor. However, be careful not to confuse smoke with steam from wet wood. Steam dissipates in the air quickly; smoke does not.

If this test indicates a problem, consider other possible factors as well, such as the weather or a change in the quality of your fuel. In warm weather, draft is weaker than it is in colder winter weather and fires can burn sluggishly. Small, hot fires are a good solution under these conditions.

Burning "green" (insufficiently seasoned) wood will result in poorer performance than burning properly seasoned fuel. You may have to run your fireplace hotter (more air) to achieve acceptable performance using green or wet wood.

Also consider any changes in your operating routine. Once you have ruled out any other possible causes for a decline in performance, inspect and clean the combustor if necessary.

Inspecting the Combustor

Use a flashlight and mirror, if necessary, to examine the combustor. If no fly ash or damage is visible, the inspection is complete. If closer examination, cleaning or replacing is needed, go to the next section.

Removing, Cleaning or Replacing the Combustor

1. Allow fireplace to cool.
2. Tap the left and right wedges back and remove. (Fig. 31)
3. Carefully slide catalyst assembly to the back of the fireplace and out of the retaining brackets.
4. Check the combustor's honeycomb-like element for a buildup of fly ash. If any is evident, take the combustor outside and clean it by blowing air gently through it. Do not push anything through the honeycomb; do not use compressed air to clear the

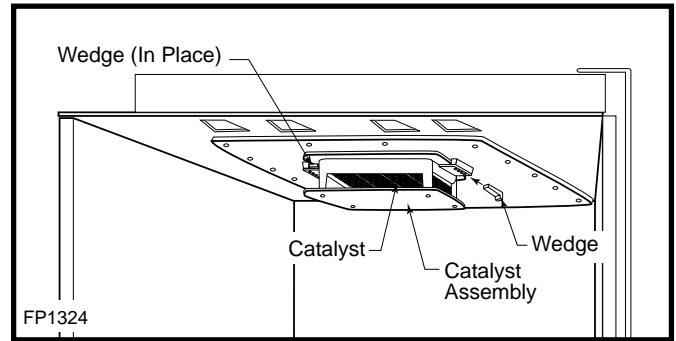

Fig. 31 Carefully tap out the wedges, then slide the Catalyst Assembly out of fireplace.

passages. Such abrasion can scrape the thin coating of platinum (the catalyst) off the ceramic base, shortening the catalyst's life and reducing its effectiveness.

5. Inspect the element for damage or degradation. Although small hairline cracks will not affect performance, the element should be essentially intact. If the element is broken in pieces or has sections missing, it should be replaced. Call your local Vermont Castings, Majestic Products authorized dealer for a replacement element.
6. If the element is in good condition and clean, reinstall it in the fireplace.

Operate the stove in your usual manner for two weeks, inspecting the chimney and the chimney connector frequently during this period.

If creosote does not build up as fast, it is likely that the performance change was caused by fly ash deposits on the catalytic element. However, continue the inspections of the chimney system for a few weeks to ensure that proper performance continues.

If you continue to find a significant creosote buildup or if you continue to see excessive smoke form the chimney, the catalytic element will need to be replaced. Contact your nearest Vermont Castings, Majestic Products authorized dealer.

NOTE: Use only the replacement catalyst supplied by a Vermont Castings, Majestic Products dealer.

How to Replace Gaskets

The EWF36A uses rope-type fiberglass gaskets to make a tight seal between some parts. With use, particularly on those parts that move, gaskets can become brittle and compressed and can begin to lose their effectiveness. These will need periodic replacement.

All of the gaskets used are made of fiberglass. The four sizes of replaceable gasket are listed below, along with their application.

Replaceable Fiberglass Gaskets

Gasket Size...	...And The Parts It Seals
1/2"	The door to the front
5/8"	Door to the hearth brick support
3/16"	The glass seal to the door
1/2"	Cat holder to top plate
1/2" Braided	Damper to top plate

Should you need to change a replaceable gasket, wait until the fire is out and the stove has cooled. Be sure to follow the standard safety procedure for working with dusty materials: Wear safety goggles and a dust mask. The procedure for replacing gaskets is the same, regardless of the gasket location. Four easily-accomplished steps are involved:

1. Remove the existing fiberglass gasket by grasping an end and pulling firmly.
2. Use a wire brush or the tip of a screwdriver to clean the channel of any remaining cement or bits of gasket.
3. Apply a thin bead of stove cement to the newly-cleaned groove.
4. Pack a new gasket into the groove. Wait until you have placed all but a couple inches from the end before you trim the end to an exact fit.
5. Place door back on fireplace, latch door and keep closed for 1/2 hour to insure cement has set.

Replacing the Door Gaskets

Remove the door by lifting it straight up off its hinge pins. Lay it face down on a padded surface.

Follow steps 1-4 as described above.

Replace Damaged Door Glass Immediately

Do not operate the fireplace with damaged glass door. Use the following procedure for glass replacement.

NOTE: Replace glass only with the replacement glass made for this unit, available from your authorized dealer.

- Remove the door and loosen the retaining clips which hold the glass to the door frame. Remove clips. Use caution when handling broken glass.
- Examine the gasket that seals the glass to the door frame. Replace if necessary with gasket obtained from your local Vermont Castings' Authorized Dealer. See the directions for gasket replacement on Page 23.
- Check the flat surface of the door frame, and clear away debris if necessary.
- Install the new glass.
- Secure the clips, being careful not to overtighten. Be sure the glass is firmly seated against the gasket.
- Replace door.

The Chimney System

A Clean Chimney System is Safer and Works Better

Although the combustion system in the EWF36A can reduce creosote formation dramatically, it is not a substitute for regular inspection and cleaning of the chimney and chimney connector.

Learn to Recognize — and Avoid — Creosote

The EWF36A has been designed to reduce creosote build-up significantly. However, regular chimney inspection and maintenance must still be performed. For safety, good stove performance, and to protect your chimney and chimney connector, inspect your chimney and chimney connector on a regular schedule. Clean the system if necessary. Failure to keep the chimney and connector system clean can result in a serious chimney fire.

When wood is burned slowly, it produces tar, organic vapors and moisture which combine to form creosote. The creosote vapors condense in the relatively cool chimney flue of a slow-burning fire. As a result, creosote residue accumulates on the flue lining. When ignited, this creosote makes an extremely hot fire within the flue system that can damage the chimney and overheat adjacent combustible material. If a significant layer of creosote has accumulated — 1/8" (3mm) or more — it should be removed to reduce the risk of a chimney fire.

If you do experience a chimney fire, act promptly to:

- Close the primary air control lever and the damper
- Get everyone out of the house.
- Call the Fire Department.

You should inspect the system every two weeks during the heating season as part of a regular maintenance schedule. To inspect the chimney, let the fireplace cool completely. Remove the termination top. Then, using a strong light, sight down into the chimney flue.

Clean the chimney using a specially designed brush the same size and shape as the flue liner. Flexible fiberglass rods are used to run the brush up and down the liner, causing any deposits to fall to the bottom of the chimney where they can be removed through the clean-out door on top of the fireplace.

If you can not do the chimney inspection yourself, contact your local Vermont Castings' Authorized Dealer, or engage a professional chimney sweep to perform the inspection and cleaning of the chimney.

The prefabricated chimney used with your fireplace should be cleaned from above using an 8" round brush and the appropriate number of extension rods for complete access.

The chimney cap first must be removed following the procedure recommended by the manufacturer. After thoroughly cleaning the chimney, reinstall the chimney cap according to the manufacturer's directions.

Maintenance Schedule

Fireplace:

Daily:

- Ash should be removed before the level reaches the top of the pan. Check each time you re-load, or at least once a day.
- Keep the area around the fireplace clear of any combustible material.

Yearly Spring Cleaning:

- Remove ash from the fire box and replace with a moisture-absorbing material (such as Kitty Litter) to keep the interior of the fireplace dry.
- Touch up painted surfaces with black paint.

Chimney Components

Component	Description	Model Number
Chimney Support	Used to support chimney for each of 30' vertical height and 6' of angled chimney run	TCS8A (8" flue)
Firestop	Required at each floor level and attic on multi-story installation	FS2A (8" straight flue) FS6A (8" 30° inclined flue)
Attic Insulation Shield	Required in Canada	FS2100HT
Traditional Top Housing	Top housing of simulated brick pattern available in red, tan or white. Appropriate adapter is required (8CA). Flashing included.	S20B (single flue)
Housing Extension	Extends Traditional Top Housing on steep pitched roofs	202036 (single flue)
Contemporary Chase Top Termination	Used to terminate chimney at the top of a chase. Flashing is not included.	SLTS8
Contemporary Flashing	Required for Contemporary Round Top termination to prevent rain entry.	8-6-12 with 8" flue 0 to 6/12 pitch 8-12-12 with 8" flue (6/12 to 12/12 pitch)
Chimney Sections	Used to build chimney systems.	8" flue 81 (1' long) 818 (1½' long) 83 (3' long) 84 (4' long)
Chimney Elbows	Used to develop offset chimney systems. Only 30° elbows are available. (Elbows packed 2 per carton - upper and lower elbow set.)	830A-2 (8" 30° flue)
Round Top Termination	Used to terminate chimney on the roof. Flashing not included.	RLTS8 (8" flue)
Extended Round Top Chase Termination	Used to terminate chimney at the top of a chase. Adapter Kit included. Flashing not included.	RLTS8L (8" flue)

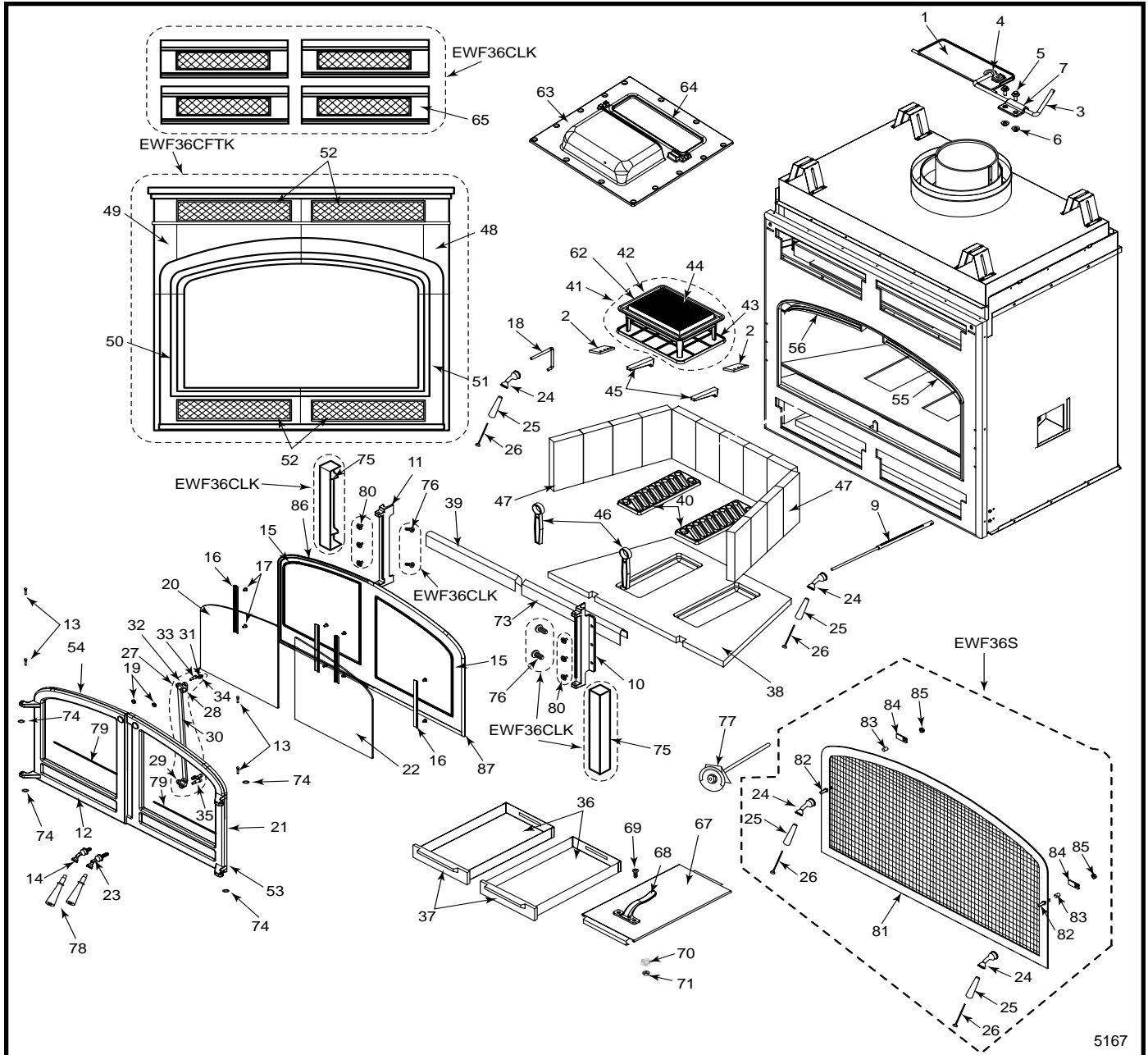

Vermont Castings, Majestic Products reserves the right to make changes in design, materials, specifications, prices and discontinue colors and products at any time, without notice.

EWF36A Fireplace

For unit FA3ECB

Ref.	Description	EWF36A
1.	Damper	20005982
2.	Gib	20005983
3.	Damper Rod	20005984
4.	Damper rod Clamp	20005985
5.	Round Head Square Neck Bolt	20005986
6.	.375 Washer	20005980
7.	Damper Clamp	20005990
9.	Damper Link Assy.	20006057
10.	Right Hinge Painted	20006302

Ref.	Description	EWF36A
11.	Left Hinge Painted	20006303
12.	Left Door Assy.	20005212
13.	Pin, Hinge	1201836
14.	Left, Door Handle Assy. Vert. Nickel	5004265
15.	Gasket, 5/16 Adhesive Backed	1203591
16.	Glass Clip	30001716
17.	Pan Hd. PH 1/4-20 x 3/8 - Blk	1200993
18.	Primary Rod	20006095
19.	Nut, Hex Jam 3/8-16 Toplk-Z	1203290
20.	Glass, Left Door - EPA Front	20005153
21.	Right Door Assy.	20005213
22.	Glass Right Door - EPA Front	20005152

EWF36A Fireplace (continued)

Ref.	Description	EWF36A
23.	Right, Door Handle Assy. Vert. Nickel	20006286
24.	Damper Steel Handle w/Screw	5004265
25.	Handle, Ceramic Blk 2.78 Lg	20006381
26.	Ov Hd Sl 1/4-20 x 3/375 Lg	1201294
27.	Linkage Assy.	20005307
28.	Pawl, Top	20005154
29.	Pawl, Bottom	20005155
30.	Link, EPA FP Front	20005156
31.	CS, Soc But hd 1/4-20 x 5/8 - Blk	1201529
32.	Nut, Hex 1/4-20 Plain	1203210
33.	5/16 Shoulder Screw, 1/4-20	20006091
34.	SS, Soc 1/4-20 x 1/4 Knl Cup Pt.	1200417
35.	3/8 Shoulder Bolt 5/16 x 1/2	20005202
36.	Ash Pan Assy.	20004915
37.	Ash Pan Front, Painted	20006300
38.	Hearth Brick	20004865
39.	Brick Ash Lip Left	20005881
40.	Ash Grate Painted	20006299
41.	Flame Holder Assy.	20005987
42.	Cast Cat Holder	20005992
43.	Cast Flamer	20005993
44.	Catalyst	20005541
45.	Wedge	20005988
46.	Andiron, Painted	20006298
47.	Firebrick	1601103
48.	Front, Upper Right EPA FP Front	20005158
49.	Front, Upper Left EPA FP Front	20005159
50.	Front, Lower Left - EPA FP Front	20005161
51.	Front, Lower Right - EPA FP Front	20005160
52.	Lattice, EPA FP - Front	20005162
53.	Door, Rt - EPA FP Front	20004742

Ref.	Description	EWF36A
54.	Door, Lt - EPA FP Front	20004741
55.	Air Wash Rt., Painted	20006296
56.	Air Wash Lt., Painted	20006297
57.	Basic Upper Rt. (not shown)	20006024
58.	Basic Upper Lt. (not shown)	20006025
59.	Basic Lower Rt. (not shown)	20006026
60.	Basic Lower Lt. (not shown)	20006027
61.	Hinge Cover (not shown)	20005994
62.	Gasket	20006295
63.	Top Cast Plate	20005979
64.	Damper Gasket	20006072
65.	Basic Universal	20006024
67.	Ash Pan Cover	20006292
68.	Handle, Ash Pan, WW/Encore	1301254
69.	1/4-20 x 3/4" FL Hd Phillips	1200881
70.	1/4" Star Washer - Black	1202461
71.	Nut, Hex 1/4-20 Plain	1203210
73.	Brick Ash Lip Right	20006085
74.	Ring, Jump	1201985
75.	Hinge Cover	20005994
76.	1/4-20 x 1/2" Phillips Rd Hd Screw	1200894
77.	Temperature Probe Assy	20006417
78.	Black Fallaway Handle	20006382
79.	Gasket 5/8" Dia. Low-D Blk	20006842
80.	1/4-20 x 1" #8 Hardness	20006847
81.	Frame & Screen Assy	20006612
82.	Stud, 3/8-16 x 2.00	20006336
83.	Spacer	20006924
84.	Screen Latch	20006337
85.	3/8-16 Lock Nut	20006339
86.	Lt. Gasket 1/2" Dia. Low-D Blk.	20006469
87.	Rt. Gasket 1/2" Dia. Low-D Blk	20006474

Optional Accessories

Fan Kit

FK26 Fan

The FK26 fan helps distribute heated air from within the firebox out into the room. The fan is controlled by a snapstat that turns power on and off as the firebox temperature rises above and falls below a preset temperature. A rheostat provides for variable fan speeds.

Specifications

115 Volt / 60Hz / .75 Amps

Maintenance

The fan itself does not require regular maintenance, however, periodic cleaning of the fan and the surrounding area is required.

Installation

1. Place fan assembly at the back of the unit between hearth supports. Attach using velcro strips provided. (Fig. 32)
2. Install thermal sensor (snapstat) on bottom of firebox by sliding between bracket and firebox.
3. Place electronic fan speed control box (rheostat) to side bracket. Fasten fan speed control box with #10 - 24 hex nuts.
4. If the EB-1 receptacle box (Pt. #ZA1200) was correctly connected when the unit was installed, the fan lead can be directly plugged into the EB-1 plug socket.



The fireplace, when installed must be electrically connected and grounded in accordance with local codes, with the current CSA C22.1 Canadian Electrical Code or for US installations, follow local codes and the National Electrical Code, ANSI/NFPA No. 70.



Any electrical rewiring of this fan must be completed by a qualified electrician. Turn off all power before hook up.

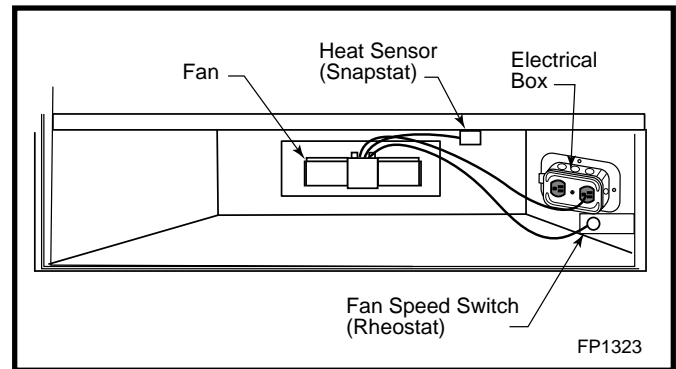

Fig. 32 FK26 fan placement.

Trim Kits

A cast face trim kit and a cast louvre kit are available to enhance the look of your EWF36A fireplace. Installation instructions are included with the kit.

Model	Description
EWF36ACFTK	Cast Face Trim Kit
EWF36ACLK	Cast Louvre Kit

Screen Kit

An optional spark screen, EWF36S, is available to allow the fireplace to be operated with the doors fully open.

NOTE: When operated with the doors open and the screen in place, the damper MUST be in the open position.

Warranty

Limited 3 Year Warranty

Vermont Castings, Majestic Products warrants that this woodburning fireplace will be free of defects in material and workmanship for a period of three years from the date you receive it, except that the catalyst, thermostat assembly, handles, glass door panels, cement, and gasketing shall be warranted as described below.

Vermont Castings, Majestic Products will repair or replace, at its option, any part found to be defective upon inspection by a Vermont Castings, Majestic Products Authorized Dealer. The customer must return the defective part or the fireplace, with shipping prepaid, to the Authorized Dealer or pay for any Authorized Dealer in-home travel fees or service charges for in-home repair work. It is the dealer's option whether the repair work will be done in the customer's home or in the dealer's shop. If, upon inspection, the damage is found to be the fault of the manufacturer, repairs will be authorized at no charge to the customer for parts and/or labor.

Any woodburning fireplace or part thereof that is repaired or replaced during the limited warranty period will be warranted under the terms of the limited warranty for a period not to exceed the remaining term of the original limited warranty or six (6) months, whichever is longer.

Limited 1 Year Warranty

The following parts of the woodburning fireplace are warranted to be free of defects in material and workmanship for a period of one year from the date you receive it: The thermostat assembly, handles, glass door panels, cement, and gasketing. Any of these items found to be defective will be repaired or replaced at no charge, upon the return of the part with postage prepaid to a Vermont Castings, Majestic Products Authorized Dealer.

Any part repaired or replaced during the limited warranty period will be warranted under the terms of the limited warranty for a period not to exceed the remaining term of the original limited warranty or six (6) months, whichever is longer.

Limited Catalyst Warranty

The catalyst will be warranted for a six year period as follows: If the original catalyst or a replacement catalyst proves defective or ceases to maintain 70% of its particulate emission reduction activity (as measured by an approved testing procedure) within 24 months from the date the EWF36A is received, the catalyst itself will be replaced free.

From 25 - 72 months a pro-rated credit will be allowed against a replacement catalyst and the cost of labor necessary for its installation at the time of replacement.

A third year (25 - 36 months) of no charge replacement will be made when combustor failure is due to thermal degradation of the substrate (crumbling of ceramic material). The customer must pay for any in-home travel fees, service charges, or transportation costs for returning the EWF36A to the Authorized Dealer.

Amount of Time Since Purchase	Credit Towards Replacement Cost
0 - 24 months	100%
25 - 36 months	50 %
37 - 48 months	30%
49 - 60 months	20%
61 - 72 months	10%

Any replacement catalyst will be warranted under the terms of the catalyst warranty for the remaining term of the original warranty. The purchaser must provide the following information in order to receive a replacement catalyst under the terms of this limited warranty:

1. Name, address and telephone number.
2. Proof of original purchase date.
3. Date of failure of catalyst.
4. Any relevant information or circumstances regarding determination of failure.
5. In addition, the owner must return the failed catalyst.

Exclusions & Limitations

1. This warranty is transferable; however, proof of original retail purchase is required.
2. This warranty does not cover misuse of the EWF36A. Misuse includes overfiring which will result if the fireplace is used in such a manner as to cause one or more of the plates to glow red. Overfiring can be identified later by warped plates and areas where the paint pigment has burned off. Overfiring in enamel fireplaces is identified by bubbling, cracking, chipping and discoloration of the porcelain enamel finish. Vermont Castings, Majestic Products offers no warranty on chipping of enamel surfaces. Inspect your woodburning fireplace prior to accepting it for any damage to the enamel.
3. This warranty does not cover misuse of the fireplace as described in the Owner's Guide, nor does it cover any fireplace which has been modified unless authorized by a Vermont Castings, Majestic Products representative in writing. This warranty does not cover damage to the fireplace caused by burning salt saturated wood, chemically treated wood, or any fuel not recommended in the Owner's Guide.
4. This warranty does not cover a fireplace repaired by someone other than a Vermont Castings, Majestic Products Authorized Dealer.
5. Damage to the unit while in transit is not covered by this warranty but is subject to a claim against the common carrier. Contact Vermont Castings, Majestic Products Authorized Dealer from whom you purchased your fireplace or Vermont Castings, Majestic Products if the purchase was direct. (Do not operate the fireplace as this may negate the ability to process the claim with the carrier.)
6. Claims are not valid where the installation does not conform to local building and fire codes or, in their absence, to the recommendations in our Owner's Guide.
7. The salt air environment of coastal areas, or a high-humidity environment, can be corrosive to the porcelain enamel finish. These conditions can cause rusting of the cast iron beneath the porcelain enamel finish, which will cause the porcelain enamel finish to flake off. This warranty does not cover damage caused by a salt air or high-humidity environment.
8. Vermont Castings, Majestic Products shall have no obligation to enhance or update any unit once manufactured.

IN NO EVENT SHALL VERMONT CASTINGS, MAJESTIC PRODUCTS BE LIABLE FOR INCIDENTAL AND CONSEQUENTIAL DAMAGES. ALL IMPLIED WARRANTIES, INCLUDING THE IMPLIED WARRANTIES OF MERCHANTABILITY AND FITNESS, ARE LIMITED TO THE DURATION OF THIS WRITTEN WARRANTY. THIS WARRANTY SUPERCEDES ALL OTHER ORAL OR WRITTEN WARRANTIES.

Some states do not allow the exclusion or limitations of incidental and consequential damages or limitations on how long an implied warranty lasts, so the above limitations may not apply to you. This warranty gives you specific rights and you may have other rights which vary from state to state.

How to Obtain Service

If a defect is noted within the warranty period, the customer should contact a Vermont Castings, Majestic Products Authorized Dealer or Vermont Castings, Majestic Products if the purchase was direct with the following information:

1. Name, address, and telephone number of the purchaser.
2. Date of purchase.
3. Serial number from the label on the back.
4. Nature of the defect or damage.
5. Any relevant information or circumstances, e.g., installation, mode of operation when defect was noted.

A warranty claim will then start in process. Vermont Castings, Majestic Products reserves the right to withhold final approval of a warranty claim pending a visual inspection of the defect by authorized representatives.